



BANCA D'ITALIA  
EUROSISTEMA

# Questioni di Economia e Finanza

(Occasional Papers)

EU-UK global value chain trade  
and the indirect costs of Brexit

by Rita Cappariello, Milan Damjanovic, Michele Mancini  
and Filippo Vergara Caffarelli

November 2018

Number

468





BANCA D'ITALIA  
EUROSISTEMA

# Questioni di Economia e Finanza

(Occasional Papers)

EU-UK global value chain trade  
and the indirect costs of Brexit

by Rita Cappariello, Milan Damjanovic, Michele Mancini  
and Filippo Vergara Caffarelli

Number 468 – November 2018

*The series Occasional Papers presents studies and documents on issues pertaining to the institutional tasks of the Bank of Italy and the Eurosystem. The Occasional Papers appear alongside the Working Papers series which are specifically aimed at providing original contributions to economic research.*

*The Occasional Papers include studies conducted within the Bank of Italy, sometimes in cooperation with the Eurosystem or other institutions. The views expressed in the studies are those of the authors and do not involve the responsibility of the institutions to which they belong.*

*The series is available online at [www.bancaditalia.it](http://www.bancaditalia.it).*

ISSN 1972-6627 (print)

ISSN 1972-6643 (online)

*Printed by the Printing and Publishing Division of the Bank of Italy*

# EU-UK GLOBAL VALUE CHAIN TRADE AND THE INDIRECT COSTS OF BREXIT

by Rita Cappariello<sup>\*</sup>, Milan Damjanović<sup>†</sup>, Michele Mancini<sup>\*</sup>  
and Filippo Vergara Caffarelli<sup>\*</sup>

## Abstract

Production networks in the European Union (EU) and the United Kingdom (UK) are highly integrated and Brexit poses a threat to supply and demand linkages across the Channel. In a world of Global Value Chains (GVCs), tariffs might be more harmful than in a world where trade is purely direct. In this paper we highlight the features of GVC-trade between the EU and the UK, disentangling the complex network of bilateral EU-UK value-added flows. Assuming that following Brexit the UK adopts the same Most-Favoured-Nation tariff schedule as the EU, we compute the direct and indirect costs of these tariffs, taking into account the EU-UK GVC-trade patterns. Tariffs would add almost 1 percentage point to the cost of manufacturing inputs in the UK, while the corresponding input cost in the EU would be only marginally affected, despite some heterogeneity at the country-level.

**JEL Classification:** D57, F13, F15.

**Keywords:** Brexit, tariffs, global value chains.

## Contents

1. Introduction .....	5
2. Related literature.....	8
3. A first look at EU-UK trade: from gross to value-added statistics.....	10
4. The EU-UK Global Value Chains: insights from bilateral exports.....	11
4.1 Sectoral GVC trade.....	16
4.2 UK and Factory Europe: intra-EU trade.....	17
5. The impact of tariffs on the EU-UK GVCs.....	18
5.1 Post-Brexit tariffs .....	20
5.2 Import-side analysis: the cost-push effect of tariffs .....	21
5.3 Export-side analysis: the cumulative resistance of export flows.....	26
6. Conclusions .....	31
References .....	34
Appendices: A. Methodology .....	37
B. Tables.....	42
C. List of countries and sectors .....	61

---

<sup>\*</sup> Bank of Italy, Directorate General for Economics, Statistics and Research.

<sup>†</sup> Bank of Slovenia, Analysis and Research Department.



# 1 Introduction<sup>1</sup>

One of the defining features of modern international trade is the pervasiveness of the global value chains (GVCs) that connect countries specialising in different phases of the same production process.<sup>2</sup> The Single Market greatly facilitated the cross-border integration of production chains in the European Union (EU), which have significantly increased in number and nowadays span borders within and outside the EU. Not surprisingly, the dense production network involving EU countries is often called ‘Factory Europe’ (Baldwin and Lopez-Gonzalez, 2015).

On March 29<sup>th</sup> 2019 the United Kingdom (UK) will withdraw from the EU. This is an unprecedented event (known as ‘Brexit’, a portmanteau word from Britain and exit) in the history of European integration, and raises many questions on the future evolution of the trade and production linkages between the two economies.<sup>3</sup>

Brexit could be a threat to the existing EU-UK GVC linkages because of tariff- and non-tariff barriers. Aside from the direct effect of tariffs, the indirect effects could be sizeable in a world of GVCs. First, imported intermediate goods are embedded in exported goods and the relative tariffs cumulate as many times as the intermediates cross the EU-UK border; thus the upstream structure of the GVC is important to assess the total cost-push effect. Second, a significant share of goods and services reach destination countries only indirectly, through other countries’ exports, and thus these intermediate goods face trade costs that are not immediately evident.

Given the existence of GVCs, traditional trade statistics no longer provide an adequate representation of supply and demand linkages, so we use Inter-Country Input-Output (ICIO) tables (specifically the WIOD<sup>4</sup> 2016 release, containing data

---

<sup>1</sup>The authors wish to thank Pietro Catte, Silvia Fabiani, Andrea Finicelli, Giuseppe Parigi, Roberto Tedeschi, and Giovanni Veronese for their useful comments. The opinions expressed in this paper are the sole responsibility of the authors and do not necessarily represent the official position of the Bank of Italy, the Bank of Slovenia, or the Eurosystem.

<sup>2</sup>See, among others, Landesmann et al. (2015), Keppel and Prettnner (2015), Amador et al. (2015) and Guerrieri and Vergara Caffarelli (2012).

<sup>3</sup>Since we place our analysis after Brexit has occurred, from now on we will use EU to refer to the Union of the 27 remaining Member States.

<sup>4</sup>See Timmer et al. (2015).

for 2014). ICIO tables have been developed by combining traditional trade statistics with national Input-Output tables in order to map production and consumption linkages between different countries. By combining these data with new tools,<sup>5</sup> we can explore a wide range of indicators based on gross and value-added trade flows of goods and services between the UK and the EU. In particular, we retrieve the portion of EU-UK trade flows related to GVC activity, and we assess the upstream and downstream linkages of the two regions, including indirect Brexit exposure.

We assume that the UK adopts the current Most-Favoured-Nation tariff schedule adopted by the EU, which is the worst case scenario for the EU-UK post Brexit relationship. We construct a tariff schedule for the EU and the UK at the sector level and, for the first time to our knowledge, at the end-use level. In this way, we focus on the hypothetical total effect of tariffs, taking into account both the direct and indirect costs related to GVC-trade.

On the import side, we retrieve the cost-push effect of post-Brexit tariffs on imported goods, by computing (see Miroudot et al., 2013) the accumulated burden of upstream tariffs for the EU (UK) imports from the UK (EU). Moreover, we show how tariffs affect the overall production costs in both regions.

On the export side, we measure the direct and indirect costs incurred by exports on their way to their destination (see Muradov, 2017). In other words, considering both direct and indirect costs uncovers how many obstacles exports face along the GVC before they reach the user.

The indirect costs of tariffs computed both from the import and the export side are clearly related to the features of the production and consumption networks between the EU and the UK. As a matter of fact, we show that the indirect costs of tariffs are correlated with the relevant measures of trade in value added, such as the foreign content in exports. This suggests that, more generally, it could be possible to quantify the cumulative tariff effects on countries and sectors with a proper analysis of the trade in value-added, even without knowing the actual level of all the tariffs.

We do not attempt to quantify the effect of tariffs on growth or macroeconomic

---

<sup>5</sup>See Borin and Mancini (2016) for a survey of recent methodologies developed to measure trade in value added and countries' participation in GVCs.



performance, rather we aim at understanding the link between the GVC structure and the direct and indirect effects of tariff costs in order to dig deeper into the ‘black box’ that empirical models, such as gravity models, are using.

We find that, after Brexit, average tariffs imposed on final products would be higher (8.6 and 5.8 per cent on average, respectively on UK and EU imported products) than those on the intermediates (3.2 and 2.8 per cent, respectively).<sup>6</sup>

As to the total cost-push effect on imported goods, we find that cumulative tariffs on EU imports from the UK would be higher than direct tariffs by around 0.4 p.p. (from 3.9 to 4.3). Thus, 11 per cent of the total cost would be driven by indirect upstream inter-linkages.

Instead, cumulative tariffs on UK imports from the EU (6 per cent) are much more in line with the direct tariffs (5.9 per cent). This is not surprising, since a very high share of UK exports to the EU embed EU products (around 9 per cent of the total, 20 per cent in motor vehicles). These goods cross the Channel – and have a tariff levied on them – twice before entering the EU. *Viceversa* the British content of EU exports to the UK is much lower (around 2 per cent), and hence the cost-push effect is negligible.

However, the cost impact of the tariffs on the economy as a whole is much higher for the UK: manufacturing input costs increase by around 0.9 p.p., two thirds due to direct tariffs, the rest to upstream linkages, while the corresponding input costs in the EU would only be marginally affected. Size matters: around one fifth of the total manufacturing inputs, imported and domestic, used by the UK come from the EU, while just 1.5 per cent of the total EU inputs are imported from the UK.

Given the density of intra-EU linkages and the sizeable share of indirect trade between the two regions, exporters in both the UK and the EU Member States face higher costs when indirect trade is taken into account. In other words, indirect routes entail tariffs that are not perceived by the exporters (as intra-EU trade is free of tariffs), but account for around 20 per cent of the total costs.

Our analysis bears some important caveats. First, it is a partial equilibrium analysis: we do not consider any possible trade creation and diversion that might

---

<sup>6</sup>It should be noted that the difference between the EU and UK direct tariffs is completely driven by sectoral composition, since the hypothetical tariff schedule is the same.

be induced by EU-UK bilateral tariffs. Secondly the persistence of tariffs between the two economies is not plausible in the long run: the expectation is that an EU-UK Free Trade Agreement will eventually be signed. Finally non-tariff barriers are not considered and are left for further research.

In summary, we are able to compute measures of cost and resistance of trade flows that take into account and are related to the EU-UK GVC structure, which may be useful in the negotiations for the future bilateral free trade agreements, and provide clear evidence of the direct and indirect costs due to Brexit.

The rest of the paper is organized as follows. Section 2 provides a review of the related literature. Section 3 presents some preliminary evidence on EU-UK GVCs. Section 4 digs deeper into the bilateral GVC relations, and the sourcing and selling strategies of the two economies. Section 5 illustrates the construction of the tariffs and calculates the cumulative impact of bilateral EU-UK tariffs. Section 6 concludes. The Appendices contain additional material.

## 2 Related literature

We borrow from various strands of the literature. After the seminal contribution by Leontief (1936), the development of ICIO tables gave new life to input-output analysis. Koopman et al. (2014) propose a new method for the decomposition of total gross exports by source and destination of their embedded value added.<sup>7</sup> Borin and Mancini (2017) introduce the ‘follow-the-value-added’ methodology that refines and corrects Koopman et al. (2014) analysis, making possible a proper investigation of the bilateral, as well as sectoral, dimension of trade flows and an analysis of a country’s backward and forward linkages within the GVC.

The average tariffs, on intermediate and final goods traded between the EU and the UK, are based on the methodology developed in Cappariello (2017).<sup>8</sup>

We compute the indirect costs of tariffs following the works of Miroudot et al. (2013), Rouzet and Miroudot (2013), and Muradov (2017). The former contribution develops a methodology to compute the accumulated burden of upstream

---

<sup>7</sup>Previously Hummels et al. (2001) and Johnson and Noguera (2012) also applied input-output analysis to the study of GVCs.

<sup>8</sup>See also Lawless and Morgenroth (2016).

tariffs for a given importer, drawing from standard cost-push analysis in the input-output literature. It shows that that, given the interdependence between services and goods in international trade, in 2009 almost one third of tariffs levied on goods were in fact applied to value added coming from services embedded in merchandise imports. The pervasiveness of the GVC structure implies that, domestically, tariff reductions in one sector generate significant productivity gains in others and, internationally, the benefits of sectoral trade agreements spill over both up- and downstream.<sup>9</sup> Using OECD-TiVA input-output tables and tariff data drawn from the UNCTAD-TRAINS database, Rouzet and Miroudot (2013) show that even small tariffs can have a significant impact on trade because of their cumulative effect.

Muradov (2017) provides a framework to compute two new measures (cumulative tariffs at origin and at destination) that proxy the obstacles which a country's exports face on their path to the user, and are useful to evaluate the indirect effects of free trade agreements on third countries. In the case of the Trans-Pacific Partnership (TPP) agreement, the author shows that non-members would reap some benefits because some of their intermediate exports reach the destination markets after being embedded in products of the TPP partners.

Other studies addressed the issue of Brexit by taking into account the existence of EU-UK GVCs, and using different analytical frameworks. Vandebussche et al. (2017) estimate a gravity model in value added, featuring sector-level input-output production linkages. Pisani and Vergara Caffarelli (2018) develop a dynamic model with tradeable intermediate goods and services (as well as intermediate non-tradeable services) calibrated for the euro area and the UK, and assess the effects of alternative tariff scenarios.<sup>10</sup>

---

<sup>9</sup>Cross-sectoral spillovers have by now become a well-known phenomenon, see for instance Carvalho and Voigtländer (2015).

<sup>10</sup>Other interesting studies on Brexit are Dhingra et al. (2017) and OECD (2016), which do not explicitly feature GVCs, and Rojas-Romagosa (2016).

### 3 A first look at EU-UK trade: from gross to value-added statistics

The first step is to investigate<sup>11</sup> the bilateral exposure of the UK, the EU and its Member States (Table B.1).<sup>12</sup> Exploiting basic accounting relationships (Leontief, 1936; Johnson and Noguera, 2012), we compare gross and net export shares. The latter are measured as value added that originated in a certain country (the exporter in value-added terms) and absorbed in a foreign market (the new ‘importer’). The UK receives about 6 per cent of EU gross exports, slightly more in value-added terms. France, Netherlands and Belgium sell between 7 and 8 per cent of their exports to the UK, while the figure for Germany and Italy is around 6 per cent. The value-added shares of these countries in the UK final demand are higher by around 0.5 p.p., meaning that the British market activates the EU productions more intensively than standard trade statistics might suggest. Malta<sup>13</sup> and Ireland are the countries for which the UK market is an extremely significant export destination, with a gross share of about 29 and 14 per cent respectively (about 26 and 13 per cent in value added terms). This result might be driven by a country’s specialisation: Amador et al. (2015) find that Luxembourg and Ireland have strong ties with the UK, Denmark and Sweden, which can be explained by common financial services specialisation both in the UK and in Luxembourg, and by Ireland headquartering many Anglo-Saxon and Nordic multinationals.

Conversely, the overall exposure of the UK to the EU is extremely high, reaching almost 40 per cent in gross terms, (32 per cent in value-added terms; Table B.1). This discrepancy suggests that the UK value added exported to the EU might often be re-exported by EU countries to some other market. We will look further into this aspect when we evaluate the bilateral trade flows and their value-

---

<sup>11</sup>The methodology employed in this section is discussed in Appendix A.1.

<sup>12</sup>The countries considered in our analysis are listed in Appendix C.

<sup>13</sup>Malta’s figures seem to be upwardly biased in WIOD data. While WIOD tables are based on official statistics only, OECD TiVA tables combine official data with firm-level evidence, providing a more reliable assessment of value added trade flows. In this latter ICIO database, the shares for Malta, both in gross and net terms, are lower by around 10 percentage points in 2011 with respect to WIOD ones. Unfortunately, the latest available year for TiVA data is 2011. Since our aim is to provide the most up-to-date picture of the EU-UK GVC, we chose to rely on WIOD.

added components. The largest UK export destinations are Germany, France and Ireland with shares of around 5 per cent, whereas in the case of Ireland the share almost halves once it is corrected for value added. Hence market size and proximity seem to be important in the selection of the destination of UK exports.

In a world of increasing production fragmentation across country borders, interconnectedness should not only be seen in terms of trade flows but also from the perspective of reciprocal production dependency. Using the ICIO framework we can examine to what extent a specific country's production depends on imported inputs from other countries.<sup>14</sup> The dependency of the EU economy on inputs from the UK is relatively small (about 1 per cent, 2 if we consider exports instead of total production; Table B.2). High dependency is found for Luxembourg (16 per cent in total, 18 for exports), Malta (8 and 10 per cent, respectively) and Ireland (about 6 per cent for both). On the contrary, the UK's dependency on the EU economy is sizeable, about 7 per cent in total production and 10 per cent for exports. The largest values are attained by imports from Germany (about 2 per cent), France and the Netherlands (about 1.5 per cent), and Italy, Ireland and Belgium (slightly less than 1 per cent).

This analysis, however, cannot quantify the actual share of trade due to the presence of GVCs, nor can it disentangle the indirect flows of goods and services between the two economies, which is the subject of the next section.

## **4 The EU-UK Global Value Chains: insights from bilateral exports**

To gauge a better understanding of EU-UK trade it is important to uncover the share of the export flows between EU countries and the UK that is related to GVC activities. Following Borin and Mancini (2017), GVC-related trade is defined as goods and services crossing more than one border, in the spirit of the definition proposed by Hummels et al. (2001). The rationale is that GVC schemes must involve at least two production stages located in different countries before the

---

<sup>14</sup>Production dependency is calculated as the imports coming from a particular country embedded in total production.

final good or service reaches the destination market (intermediate goods crossing just one border are not part of GVC-trade).

Figure 1 illustrates the decomposition of (gross) bilateral export flows into its domestic and foreign components (see Borin and Mancini, 2017).

Figure 1: Decomposition of bilateral exports

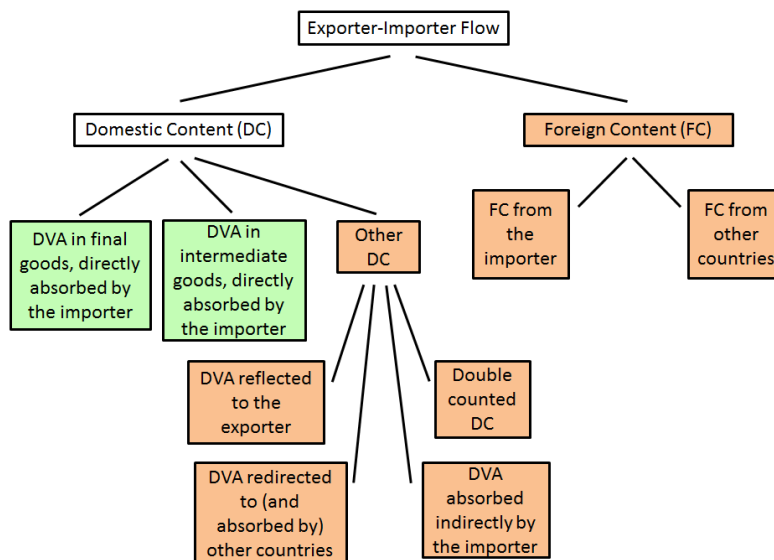

Note: Traditional trade is in green, GVC trade in orange.  
Based on Borin and Mancini (2017).

The domestic component of bilateral export can be further divided into three parts i) domestic value added (DVA) in final goods directly absorbed by the importing country, ii) DVA in intermediate goods directly absorbed by the importing country, and iii) other domestic content components. The other domestic content components are 1) DVA reflected (i.e. re-sold) to the exporting country, 2) DVA redirected to, and absorbed by other countries, 3) DVA indirectly absorbed by the importer, and 4) double counting. According to our definition of GVC trade, DVA in both final and intermediate goods directly absorbed by the importing country constitutes a traditional trade flow. Instead, DVA reflected to the exporting country, DVA redirected to other countries, DVA indirectly absorbed by the importer, and double counting are a part of GVC trade: the first and the fourth items travel

back and forth across the exporter-importer border,<sup>15</sup> whereas the second and the third items pass both the exporter-importer border and the one between the importer and a third country.

The foreign component of bilateral export flows is divided into two parts depending on its origin, from the importer and from other countries, and both belong to GVC trade.

Since our focus is on the EU as a whole, and not on single member countries, we exclude all the intra-EU borders, and compute the GVC trade as defined above. It turns out that the share of EU exports to the UK related to GVCs is about 35 per cent (40 per cent for UK exports to the EU). Thus, even without considering intra-EU borders, more than one third of the trade flows between the EU area and UK still consists of goods and services that cross at least two borders (the Channel and some other extra-EU border, or the Channel at least twice).

Figure 2 depicts the three elements of bilateral export flows, Ricardian trade (65.4 per cent for the EU and 59.6 per cent for the UK), domestic value added in GVC trade (15.6 and 21.8 per cent, respectively), and foreign content (19 and 18.6 per cent, respectively). The upstream linkages might be evaluated by looking at the foreign content from other countries embedded in the bilateral exports between the EU and the UK, the downstream linkages by looking at where the domestic value added is absorbed, either in the exporting country itself (reflected domestic value added) or redirected to other economies.

By exploiting the Borin and Mancini (2017) decomposition, we are able to identify in each particular bilateral export flow: i) the country where the foreign content originated; and ii) the destination market, where the final good is ultimately absorbed (Figure 3).

First, we look at the upstream structure, retrieving the countries of origin of the foreign content embedded in the bilateral flows between UK and EU, to assess the different sourcing strategies of the two economies (Figure 4). In total, around 20 per cent of UK and EU bilateral exports are made up of goods and services that have been produced outside the exporting country. More specifically, about 9 per cent of UK exports to the EU consist of intermediate products that are actually

---

<sup>15</sup>More precisely, double counting is DVA that crosses a producer's border at least twice (Koopman et al., 2014).

Figure 2: Decomposition of EU-UK bilateral exports

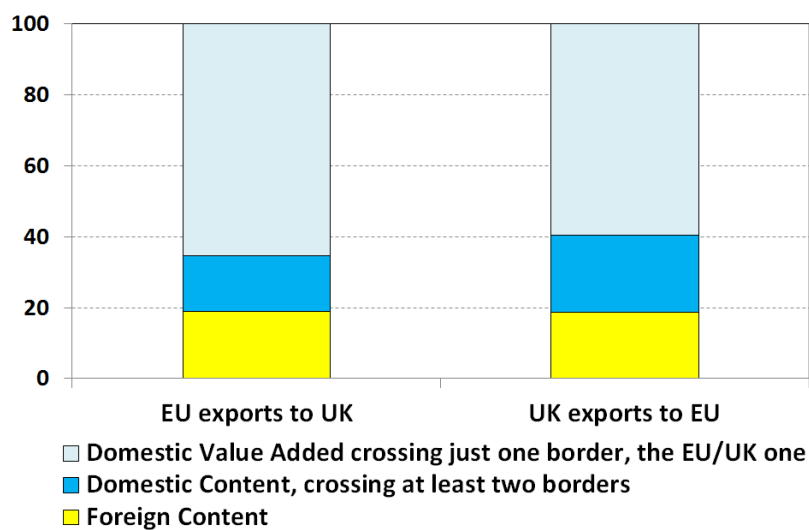

Note: percentage points. Source: Authors' calculations based on WIOD data.

Figure 3: Bilateral exports from a GVC perspective

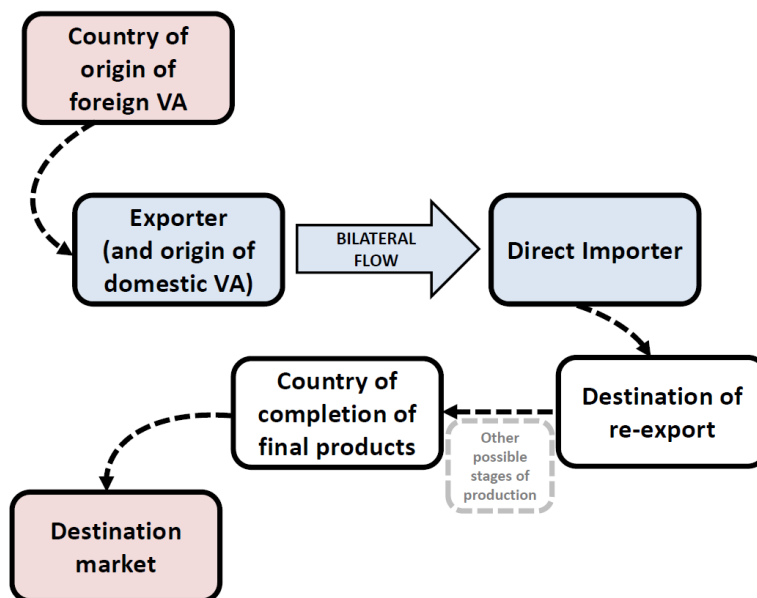



produced in the EU, while the UK foreign-content share in EU exports to the UK is just 2 per cent. Thus, some of the production stages, carried on within UK and needed to produce goods and services that will be exported to the EU, rely heavily on intermediates from the EU itself. Almost 8 per cent of EU exports to the UK originated in emerging market economies.

Figure 4: Foreign content in bilateral exports, by country of origin

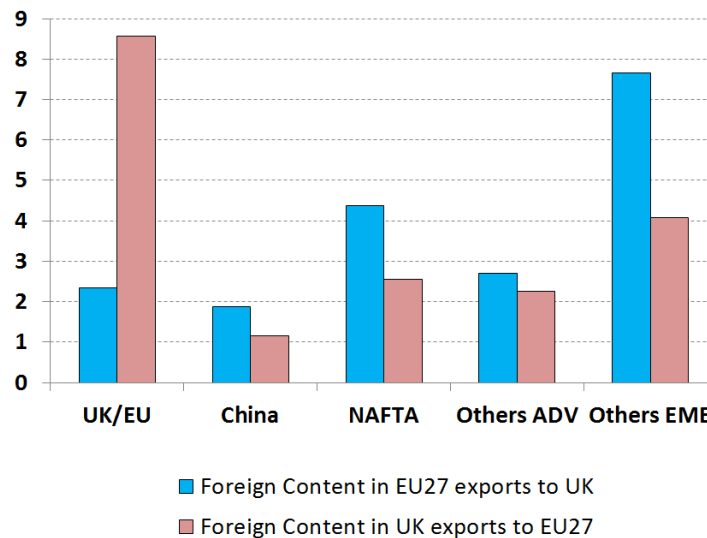

Note: percentage points. Source: Authors' calculations on WIOD data.

Following the value added also allows us to uncover downstream linkages of the EU and the UK economies. Although traditional trade statistics cannot shed light on this aspect, identifying the ultimate destination market of bilateral trade flows could be quite important, especially if tariffs are passed through to final consumers. It turns out that 18 per cent of the UK exports to the EU are redirected to some other final market (Figure 5), suggesting that the UK exploits Factory Europe as a hub to reach other markets, such as emerging-market economies (11 per cent of the total exports from the UK to the EU) and NAFTA countries (3 per cent). It seems that the opposite is not true for the EU. Interestingly, more than 4 per cent of EU exports to the UK come back to be consumed in the EU (reflection), therefore crossing the Channel twice.

Figure 5: Re-exported domestic value-added in bilateral exports, by final destination

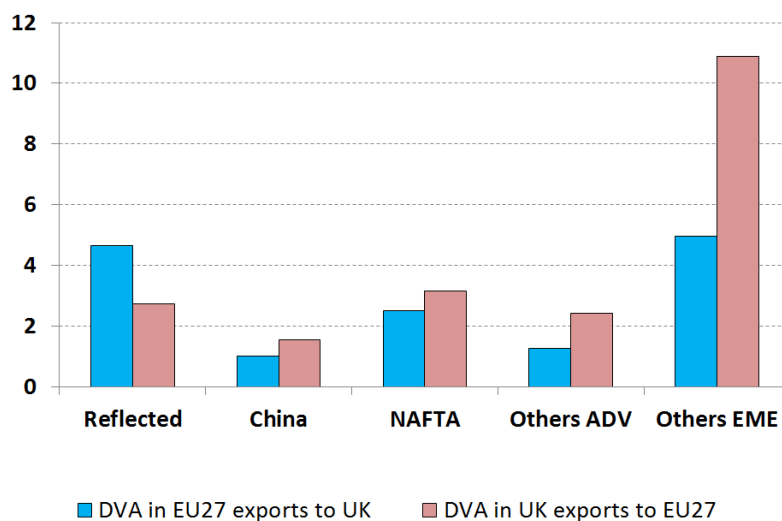

Note: percentage points. Source: Authors' calculations on WIOD data.

#### 4.1 Sectoral GVC trade

The follow-the-value-added methodology allows us to decompose bilateral export flows into their value-added components and to identify their origin and destination, also at the sector level.<sup>16</sup> Tables B.3 and B.4 present the sectoral GVC-related bilateral exports for the UK and the EU, respectively. The sectors with the highest overall share of GVC-related trade in bilateral exports are basic metals (67 per cent for the UK and 68.4 for the EU), coke and petroleum (67.7 per cent for the UK and 63.2 for the EU), and forestry and logging (60.8 per cent for the UK) and chemical products (53.5 per cent for the EU). This is not surprising, since these types of production are usually more upstream in the manufacturing process, and are used as inputs in more downstream sectors in the same and/or in foreign markets.

As discussed above, domestic value added in exports can be reflected back to the exporting country. The largest shares of British value added reflected into the UK are in forestry and logging, crop and animal production, and paper products

<sup>16</sup>See Appendix C for the list of sectors.

(8.8, 6.9, and 4.9 per cent respectively), whose share of domestic value added are 30.6, 24.8 and 23.1 per cent, respectively (Table B.3). EU value added exported to the UK and then reflected back to the EU is highest in basic metals, chemical products, and mining and quarrying (11, 9.6 and 8.5 per cent, respectively), which are also the sectors with the largest domestic content (Table B.4).

We can also obtain some insight regarding the upstream structure of these sectoral trade flows by looking at the other region's value added in the bilateral export flows. For the EU the top sectors in terms of UK value-added content in exports to the UK are crop and animal production, food products, and coke and petroleum (5.7, 4.3 and 3.8 per cent, respectively), while computer and optical products, one of the sectors with the highest foreign content has a share of just 1.9 per cent of UK value added (Table B.4). The first three sectors combined constitute 21.6 per cent of European exports to the UK. For the UK, the share of EU value-added content in the bilateral exports to the EU is much higher. Interestingly, the UK sectoral exports to the EU that contain the largest shares of European value added are motor vehicles, chemical products, and basic metals (20.4, 17.8, and 14.9 per cent, respectively; Table B.3). These three sectors account for 27.8 per cent of British exports to the EU. In section 5 we will show that this evidence relates to the accumulated burden of upstream tariffs for a given importing sector. In particular, these goods cross the Channel twice and thus are subject to post-Brexit tariffs more than once.

## 4.2 UK and Factory Europe: intra-EU trade

In Table B.5 we show how UK goods and services reach the EU countries as final markets. On average, around 75 per cent of UK value-added is delivered to a given EU country directly. However, around 18 per cent is first exported to some other economy in *Factory Europe*, and it only reaches the destination market after some processing stages. There is a high level of heterogeneity: while the indirect trade to EA-3 countries (Germany, France and Italy) is in line with the average, more than one third of UK products destined for Austria and Eastern EU countries (in particular Slovakia, Slovenia and, to a lesser extent, Romania) reaches those countries indirectly, embedded in the exports of other Factory Europe economies.

Let us now consider how EU countries' value added reaches the UK. The indirect trade is still substantial, around 17 per cent (Table B.5). Not surprisingly, Ireland delivers the vast majority of its goods and services to the UK in a direct way, and Malta shows a very low degree of indirect trade too. Again, some Eastern EU economies, such as Slovenia, Romania and the Czech Republic take advantage of the EU network to process their products and reach the UK.

Table B.6 presents direct and indirect trade between the UK and the EU Member States as a share of GDP. This shows what part of the exporter's GDP is activated directly or indirectly by the demand of the importing country, and indicates the trade exposure in the event of a hard Brexit. The overall exposure to the UK is highest for Malta, Ireland, the Netherlands, and Slovakia (12.4, 7.5, 3.4 and 3.3 per cent respectively); this is due to the large direct exposure of these countries to UK demand (12, 7, 2.6 and 2.6 per cent, respectively). Interestingly for Cyprus the indirect exposure (1.1 per cent) is higher than the direct one (1 per cent); other countries with high indirect exposures are Luxembourg, the Czech Republic, the Netherlands, and Hungary (1.0, 0.8, 0.7, 0.7 per cent, respectively). Conversely, the UK is mostly exposed to the demand in Germany, France, Italy, and Ireland (1.4, 1.3, 0.7, and 0.6 per cent, respectively), mainly through direct trade linkages.

In section 5, we will relate these results to a measure of indirect obstacles that EU and UK products have to face to reach their destinations. In fact, since EU and UK products are embedded in other Factory Europe countries' exports, they will indirectly face a trade cost that is not immediately evident.

## 5 The impact of tariffs on the EU-UK GVCs

In the previous sections we highlighted some of the features of GVC-trade between the EU and the UK. Here we investigate the impact of tariffs.

We first compute the hypothetical tariff schedule that will be in place after Brexit: this is the traditional manner in which the trade cost of Brexit has been evaluated (Cappariello, 2017; Lawless and Morgenroth, 2016), which we innovate by distinguishing tariffs according to the end-use of the goods (final or intermediate). Then we show how the network structure of trade flows and the interconnections between the two regions would affect the post-Brexit accumulation of trade

costs on intermediate goods, i.e. the indirect tariffs due to the presence of GVC-trade, on top of the direct tariffs. In this way we are able to extend traditional analyses on trade costs of Brexit, explicitly taking into account two features of GVC- trade flows: a) exported intermediate goods embed imported intermediates and their relative tariffs; and b) a significant share of goods and services reach destination countries only indirectly, through other countries' exports, and thus are subject to tariffs that are not immediately evident. We apply two different methodologies, developed in the literature by Rouzet and Miroudot (2013) and Muradov (2017), respectively.

Rouzet and Miroudot (2013) compute the 'cumulative tariff' (i.e. the accumulated burden of upstream tariffs for a given importer), which quantifies the total cost-push effect of direct and indirect tariffs, taking into account the upstream GVC structure (in section 5.2 we compute the cumulative tariff on post-Brexit tariffs on EU-UK trade).<sup>17</sup>

Instead, Muradov (2017) stresses the importance of indirect bilateral trade flows and proposes two alternative measures to account for the related costs, the cumulative tariff at origin and at destination. If we consider any given country pair, exports originating in the first country (called the producer) can take many possible paths to reach the second (the user): the producer can export directly to the user or can do it indirectly, i.e. its exports can reach the user by being embedded in third countries' exports to the latter. The cumulative tariff at origin traces the direct and indirect cost levied on exports as soon as they leave the producer. Conversely, cumulative tariff at destination traces the direct and indirect costs of the producer's exports upon entry into the user country. Differently from Rouzet and Miroudot (2013), these measures cannot be interpreted as cost-push effects such as the cumulative tariff, but as a proxy of the relative resistance of trade flows, since they measure the direct and indirect costs that an exported product has to face on its path from the producer to the user (see section 5.3).

Our first step is to compute the post-Brexit tariffs.

---

<sup>17</sup>See also Johnson (2017) for an up-to-date review of the cost-push effect of trade costs.

## 5.1 Post-Brexit tariffs

In order to estimate the average tariffs that would affect both the consumers and the producers in each EU Member State and in the UK after Brexit, we construct a tariff schedule for the EU and the UK at the sector level and, for the first time to our knowledge, at the end-use level. We assume that following Brexit the UK adopts the current EU tariffs; in other words, the trade tariffs that the EU currently applies to countries with which there is no free trade agreement will be applied between the EU and the UK (as well as between the UK and other third countries).<sup>18</sup> These are the Most-Favoured-Nation tariffs (MFN). We are therefore considering the worst case scenario in terms of the post-Brexit EU-UK relationship. Indeed, if a free trade agreement is struck, tariffs on bilateral trade will be lower, potentially even zero.

Tariffs are public information. Yet the calculation of average tariffs is far from straightforward and is described in Appendix A.2. Table B.7 (Table B.8) lists the average bilateral tariffs that, according to our estimates, would be applied to the EU (UK) imports from the UK (EU) at the sector level, with the detail for final use and intermediates. Given the product composition of bilateral trade in 2014 (latest available year of the WIOD ICIO tables), the average duty imposed by the UK on goods imported from the EU would be 5.9 per cent whereas the duty imposed by the EU on British goods would be 3.9 per cent. As expected, the duties imposed on final products would be higher (8.6 and 5.8 per cent on average respectively on UK and EU imported products) than those on the intermediates (3.2 and 2.8 per cent).

The high discrepancy in tariff rates between final and intermediate use even within the same industry confirms the importance of taking into account all the stages of the global value chain for the calculation of the impact of potential EU-UK tariffs along the production linkages.

Tables B.7 and B.8 also show that the EU imports a relatively high share of intermediate inputs from the UK: almost 63 per cent of the value of imports from the UK is constituted by goods subsequently processed in the EU economies –

---

<sup>18</sup>This is consistent with the joint letter to the WTO members from the EU and the UK of 11<sup>th</sup> October 2017 in which the UK stated that it ‘intends to replicate as far as possible its obligations under the current commitments of the EU.’

especially chemical, mining and metal products (Table B.7). On the contrary, the British economy imports relatively more final goods, mainly motor vehicles and food products, from the EU. Indeed, half of the value of total imports from the EU is given by final goods (Table B.8).

Tariffs can also be aggregated at the country level by using sectoral import shares. Tables B.9 and B.10 present the average tariffs for intermediate, final and total bilateral imports for the UK and the EU Member States. There is a very high cross-country variability that is driven by the underlying sectoral specialisation of each country.<sup>19</sup> Moreover tariffs on final goods are higher and even more variable than those on intermediate goods.

## 5.2 Import-side analysis: the cost-push effect of tariffs

In this section we compute the cumulative tariffs that EU and UK imports would have to face after Brexit, comparing the results with the direct tariffs. Moreover, we show how tariffs affect the overall production costs in the two regions.<sup>20</sup>

In Figure 6 we show a graphical representation of the cumulative tariff by Rouzet and Miroudot (2013). In this simplified scheme, there are only four countries: E (last exporter), M (importer), TC1 and TC2 (third countries). Country M imports a unit of a good, paying the direct tariff  $t_{E,M}$ . However, the last exporter (E), in order to produce exports, has sourced inputs from M itself and from third countries TC1 and TC2, paying the corresponding tariffs. In turn, these three countries have already paid tariffs embedded in their export flows, and this process could be iterated even further upstream. Thus, imports to country M embed direct tariffs  $t_{E,M}$ , and all the indirect tariffs incurred in the upstream value chain, weighted by the amount of imports needed to produce exports. Then, we obtain the share of the indirect costs levied on a particular import flow as the ratio between the indirect costs and total cost-push effect, which also takes into account

---

<sup>19</sup>We refer the interested reader to Cappariello (2017), who presents a more detailed analysis of average country tariffs.

<sup>20</sup>Owing to the changing nature of GVCs we also performed this analysis with the ICIO data for 2000, provided by the WIOD. The results are basically unchanged, indicating that within Europe the GVCs are pretty stable. This is consistent with the history of GVCs in Europe that developed in the 1990's, when Eastern European countries entered into Transition (Guerrieri and Vergara Caffarelli, 2012).

the direct trade costs.<sup>21</sup>

Figure 6: Graphical representation of the Rouzet and Miroudot (2013) cumulative tariff

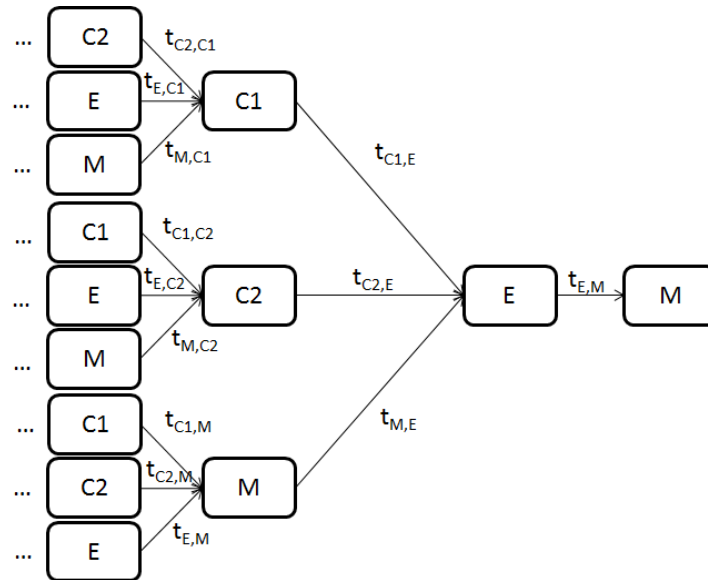

In principle, with a complete tariff schedule between all country-sector pairs in the world, it is possible to compute a cumulative tariff, which takes into account the entire structure of the international production network.<sup>22</sup> This is not the aim of our work. In fact, our emphasis is just on the EU-UK border, and the only tariff that we consider is the one that will probably be in place after Brexit. Hence, in this particular setting, tariffs are cumulated only when goods and services cross the EU-UK border more than once.

As an example, consider the following scenario. The EU and the UK charge the same tariff equal to 5 per cent on both intermediate and final imports. The UK imports €10 of intermediates from the EU, combines them with another €10 of British value added and exports the final product back to the EU. By assumption a tariff of 5 per cent is charged on (gross) imports on each border crossing. Hence UK

<sup>21</sup>For a formal overview of the cumulative tariffs see Appendix A.3.

<sup>22</sup>See Rouzet and Miroudot (2013). They compute cumulative tariffs by exploiting WIOD Input-Output tables and tariffs between each country-sector pair in the WIOD tables based on the UNCTAD-TRAINS database.



producers pay €10.5 for the EU intermediate goods. If the UK producer passes-through the tariff entirely, the export price of the final goods is €20.5. The EU then charges a 5 per cent tariff and the EU consumer consequently pays €21.525 for the imported final good, as opposed to the no-tariff price of €20. Hence a 5 per cent tariff on both intermediate and final imports implies a price increase for the final consumer equal to 7.625 per cent. Had there been no GVC relationship between the EU and the UK (i.e., if the final good was 100 per cent British value added) the impact of tariffs would have been just 5 per cent (i.e. the EU tariff on final imports from the UK). This is the tariff magnification effect of back-and-forth trade.

There is only one case in which there is no tariff magnification effect: this occurs if UK producers fully absorb import tariffs into their profits, and do not pass them through. In this case the export price of the final good from the UK to the EU would be €20 (as in the no-tariff scenario) and the final price €21. Yet UK firms' profits would be reduced by 5 per cent. Since firms' behaviour and, in particular, their pricing strategy is a complex issue that falls beyond the scope of this preliminary investigation, we assume that both European and British firms fully pass tariffs through into prices, since in a Leontief framework firms are price setters. This is also consistent with our partial-equilibrium approach and the nature of this study as an impact assessment exercise.<sup>23</sup>

We are now ready to compute the cumulative tariffs induced by the new post-Brexit tariffs, given the existing EU-UK GVC as mapped in the WIOD.

Tables B.11 and B.12 show the cumulative tariffs on EU and UK merchandise imports by sector, respectively. The cost increase of EU imports from the UK turns out to be sizeable: while the average direct tariff is 3.88 per cent, the total cost-push effect is 4.3 per cent (Table B.11). Thus, all else being equal, around 10.8 per cent of the total cost-increase of EU imports after Brexit is due to indirect backward inter-linkages.

Sectoral heterogeneity is substantial. The total cost of EU imports of intermediate goods in the motor-vehicle and chemical sectors, which account for around 20

---

<sup>23</sup>In the longer run firms will consider the existence of tariffs in their sourcing decisions and may consequently restructure their GVCs, substituting suppliers across the Channel with others located in third countries.

per cent of total imports of intermediate goods from the UK, increases by around 1 p.p., and the indirect effect accounts for around 16 per cent of the total increase. Traditional EU sectors seem less affected: indirect tariffs on food and textiles account for less than 0.45 p.p. of total cost-increase. In two sectors, mining and paper products, direct tariffs on intermediate goods, both for EU and UK imports, are almost zero, and the total costs are almost entirely due to the indirect backward linkages.

In turn, the indirect cost increase of UK imports would be small: the difference between direct and total tariffs is just 0.07 p.p. (Table B.12).

The total cost increase is purely indirect for the service sectors (Table B.13). Despite direct tariffs being absent by definition, service producers pay tariffs on imported intermediate goods. Again, the cost increase is on average around 0.1 p.p. for EU imports of services and even smaller for UK imports.

In Table B.14 we show the direct and indirect cost increase for different EU member countries. As regards the UK, only the cost of the imports from Ireland seems to be higher due to indirect backward linkages (by around 0.33 p.p.). Instead, indirect costs on EU imports from the UK are higher on average, and range from 0.53 p.p. for Austria to 0.35 p.p. for Denmark.

The magnification of direct costs measured as cumulative tariffs is clearly related to backward participation in the regional value chain. The higher indirect cost for EU importers is due to the fact that the EU exploits the UK to perform some processing stages and imports back these products. In this way, these intermediate goods cross the Channel twice, and thus have tariffs levied on them both directly, the first time that the goods are imported by the UK, and indirectly, once the goods are embedded in UK products imported by the EU. A proxy of this back-and-forth trade between the two regions is offered by the UK (EU) foreign value added in the bilateral exports to the EU (UK), seen in section 4, which is positively correlated with the indirect cost-push effect at the sectoral level (Figure 7). This evidence suggests that if these tariffs are levied on EU imports after Brexit, the subsequent cost increase might induce some EU producers to divert exports from the UK to other EU countries, in order to perform these processing stages within Factory Europe.

We can also compute the magnification effect on the trade flows with third

Figure 7: The other region's foreign content in exports and the indirect cost effect

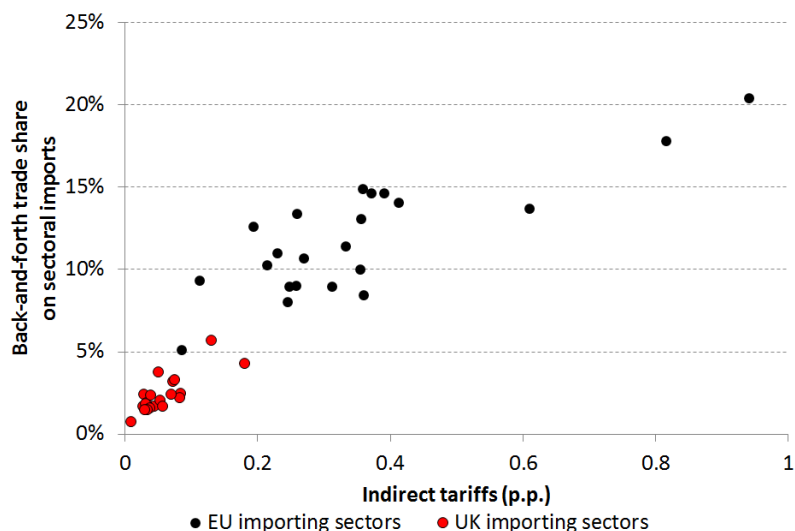

Source: Calculations based on WTO-IDB database and ITC Market Access Map for tariffs, and Comtrade and WIOD for trade.

countries. Table B.15 presents the cumulative tariffs that would arise in European and British exports and imports with other countries. For the UK, tariff magnification will raise export costs towards Russia, Turkey and Mexico (by half of a percentage point), as well as towards large Commonwealth countries such as Australia (0.45 p.p.), India (0.36 p.p.) and Canada (0.32 p.p.),<sup>24</sup> whereas for EU exports the impact is very small. Not surprisingly, the effect of cumulated EU-UK tariffs on the import side is practically nil for both economies.

Finally, using the same analytical framework of the tariff magnification effect, we can compute the impact of (cumulative) tariffs on domestic production costs. Even if tariffs are only levied on goods and services crossing the Channel, it should be clear that any intermediate goods coming from any country might directly or indirectly embed EU or UK goods on which a tariff has been imposed. Moreover, even domestic inputs embed intermediates that have been imported from the other side of the Channel.

<sup>24</sup>The effect on Canada is likely to be an underestimate because the latest available data, which we use, are for 2014, but in the meantime the Comprehensive Economic and Trade Agreement has entered into force, albeit provisionally.

In Table B.16 we show, for every country, the total cost increase of its manufacturing inputs, regardless of their origin.<sup>25</sup> It turns out that in the UK the cost of manufacturing inputs increases by almost 0.9 p.p. when domestic and global value chains are taken into account, while the direct effect of tariffs is around 0.6 p.p. Instead, the overall impact on EU costs would be 0.08 p.p. However, the cost-increase is very varied across EU countries, and particularly high for Ireland (around 1 p.p.). These results are not surprising: around one fifth of the total manufacturing inputs, imported and domestic, used by the UK come from the EU, while just 1.5 per cent of the total EU inputs are imported from the UK. In other words, size matters, and this is true also at the sectoral level (Table B.17).

### 5.3 Export-side analysis: the cumulative resistance of export flows

In order to complement the analysis on the effect of post-Brexit tariffs, let us now adopt a totally different perspective, i.e. that of the exporter. In this section we will try to answer the following question: What obstacles will exports face on their way to their destination? Here we aim at investigating this issue from the point of view of both the EU and the UK; we will concentrate on bilateral direct and indirect export flows, and consider the effect of tariffs on the EU-UK border after Brexit.

In this context, we consider the ‘full’ bilateral relations between EU Member States and the UK by computing the cumulative tariffs at both the origin and the destination, as developed by Muradov (2017),<sup>26</sup> which allows us to obtain an index of the *resistance* of trade flows, defined as the sum of direct and indirect costs that an exported product has to face on its path from the producer to the user. The intuition is very clear: in a GVC world one country’s exports reach another both directly and indirectly, embedded in other country’s exports (possibly more than one); in a traditional, ‘Ricardian’ world, trade is just direct. Then, comparing direct and indirect costs determines how much additional resistance exports face

---

<sup>25</sup>If we hold the hypothesis of a full pass-through of tariffs to be true, these figures for the cost increases are actual increases in the producers’ prices.

<sup>26</sup>See Muradov (2017) for a formal derivation of these measures.

along the GVC to reach their destination.

The logic behind this exercise is simple. Final or intermediate demand in the UK activates both direct and indirect exports from the EU. Direct exports directly satisfy the demand in the UK. Indirect exports are parts and components supplied to the (last) exporter in the UK. The opposite happens to EU exports. As noted in section 4.2, the high degree of interconnectedness within Factory Europe makes it worth investigating indirect as well as direct exports.

In our specific context we are interested in the impact of EU-UK bilateral tariffs, as these will be the only changes in the tariff structure after Brexit.<sup>27</sup> In particular no tariff will be introduced within the Single Market and the transactions affected by the new tariffs will just be those involving the UK, on the one side, and any EU Member State, on the other.

Hence British exporters will face the new tariffs as soon as their goods leave the UK, while European exporters will face the new tariffs only when their goods enter the UK. Consequently, when we focus on the British exports to the EU we will compute the cumulative tariffs at the origin, while we will compute the cumulative tariffs at the destination for the EU exports to the UK.

### 5.3.1 Resistance (at origin) of UK exports

Figure 8 provides an illustration of the typical flow of UK exports to a given EU Member State. In order to record the tariffs levied on British intermediate goods used by a given EU Member State (MS1), our analysis focuses on the UK and the perspective is forward-looking. The key point is that indirect tariffs on intermediate goods that will end up in MS1 are applied as soon as inputs leave the UK. Apart from the direct tariff ( $t_{UK,MS1}$ ), the indirect tariffs ( $t_{UK,MS2}$ ,  $t_{UK,MS3}$ ) increase the resistance that these intermediates have to face to be delivered to MS1. Note that no new tariff is applied to British exports to third countries, for instance to TC1.

In Table B.18 we show the current dollar values of both direct and indirect tariffs at origin for British exports to the EU Member States.

---

<sup>27</sup>It may be that the tariffs the UK faces vis-à-vis third countries change as well, but we abstract from that.

Figure 8: Graphical representation of the Muradov (2017) cumulative tariff at the origin

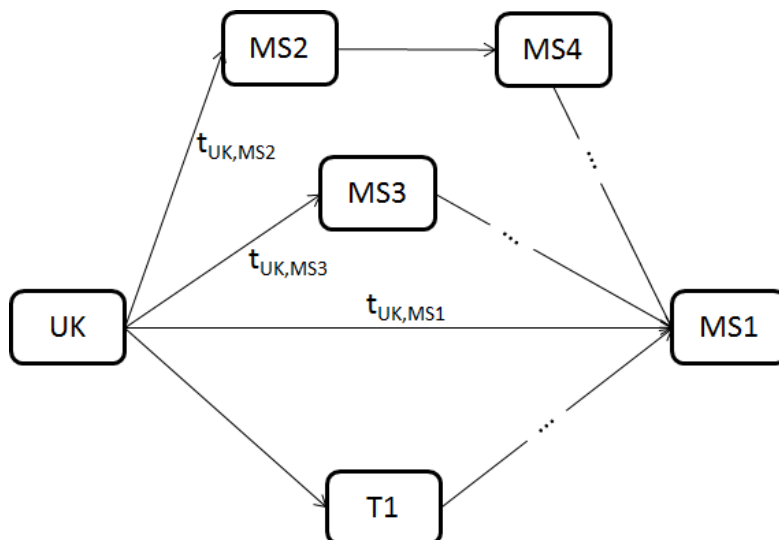

Indirect tariffs amount to a substantial part of the overall burden of the cumulative tariffs at the origin (around 20 per cent, on average). In fact, a significant share of UK intermediate goods are first exported to an EU country, and then reach the EU destination only indirectly, as highlighted in section 4.2. Thus tariffs are levied not only on the direct trade from the UK to a certain EU market, but also indirectly, since UK products are first exported to other EU countries before reaching another EU destination.

For instance, exports to Germany have the largest burden levied on them in terms of both direct (\$526.1 million) and indirect tariffs (\$167.3 million), consistently with the central position of the German economy in Factory Europe. Given its proximity to the UK, the tariff burden with Ireland is essentially direct, whereas for Slovakia the burden of direct and indirect tariffs is approximately the same (almost \$ 10 million).

As a matter of fact, the indirect tariff takes into account the fact that UK exploits the production structure of Factory Europe in order to reach a particular EU Member State. This reasoning is confirmed by the correlation between the indirect trade from the UK to EU countries through other EU countries' exports,

computed in section 4.2, and the resistance measure (Figure 9).

Figure 9: Indirect UK trade to the EU and resistance by the origin

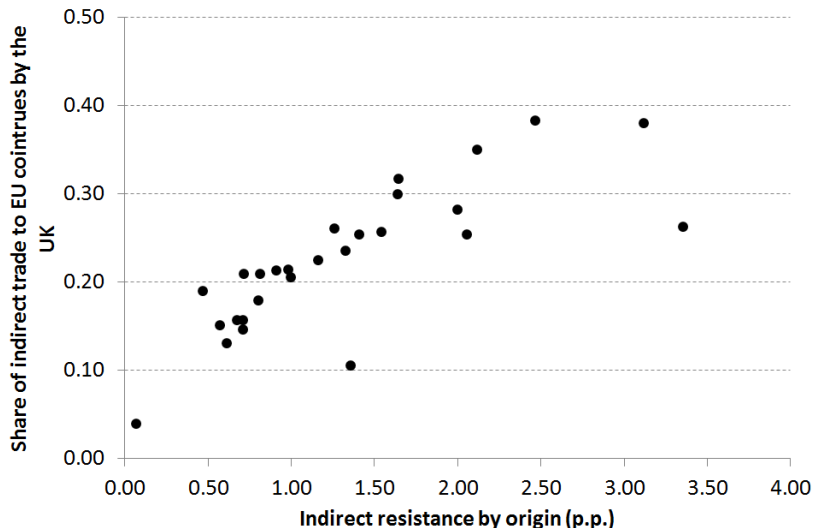

Source: Calculations based on WTO-IDB database and ITC Market Access Map for tariffs, and Comtrade and WIOD for trade.

### 5.3.2 Resistance (at destination) of EU exports

Figure 10 depicts the paths along which products of a given Member State, MS1, reach the UK. Now we focus on the UK and indirect tariffs are recorded with a backward-looking perspective, when embodied inputs reach the UK. It does not matter whether these intermediate goods are directly exported by MS1 or another EU Member State; the relevant unit of observation is the last shipment of goods and services. In this way, although by definition tariffs do not apply to services, if the last shipment concerns exports that embed services produced in MS1, an indirect tariff will be applied to them. Hence the relevant tariffs here are the direct tariff ( $t_{MS1,UK}$ ) and the indirect tariffs through other EU countries ( $t_{MS3,UK}$  and  $t_{MS4,UK}$ ). Again, any path entering the UK from third countries makes no contribution, since we assume that those tariffs will not be affected by Brexit.

Table B.19 shows the dollar values of direct and indirect tariffs at destination for the EU products sold in the UK. The indirect tariff burden on UK imports

Figure 10: Graphical representation of the Muradov (2017) cumulative tariff at the destination

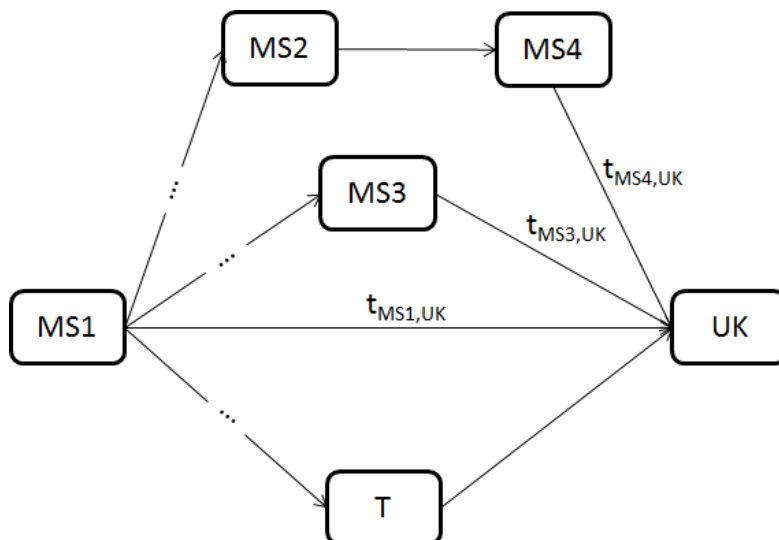

computed with this latter methodology is not negligible: it accounts for 25 per cent of the total cost faced by British users of EU intermediates. German direct and indirect exports to the UK face the largest tariff burden (\$1248.1 and \$357.3 million, respectively), while Irish goods are essentially charged the direct tariffs only (amounting to \$417 million). Conversely, small countries, such as Cyprus, Luxembourg, Malta, Slovenia and Slovakia face very high indirect tariffs.

The indirect resistance for EU products is driven by the fact that EU countries deliver around 25 per cent of their products to the UK in an indirect way, through other EU countries' exports, as highlighted in section 4.2. Thus, these intermediate goods face an indirect tariff that is not immediately perceived by the EU exporting country. This is confirmed by the fact that the indirect trade to the UK through other EU countries exports, computed in section 4.2, is related to the resistance measure (Figure 11).

Moreover, EU services also face tariffs at destination, which are entirely indirect, since they are embedded in other EU countries' intermediate goods exported to the UK.<sup>28</sup>

<sup>28</sup>Conversely, UK services exported to the EU face no tariff by definition.



Figure 11: IndirectEU trade to the UK and resistance by the destination

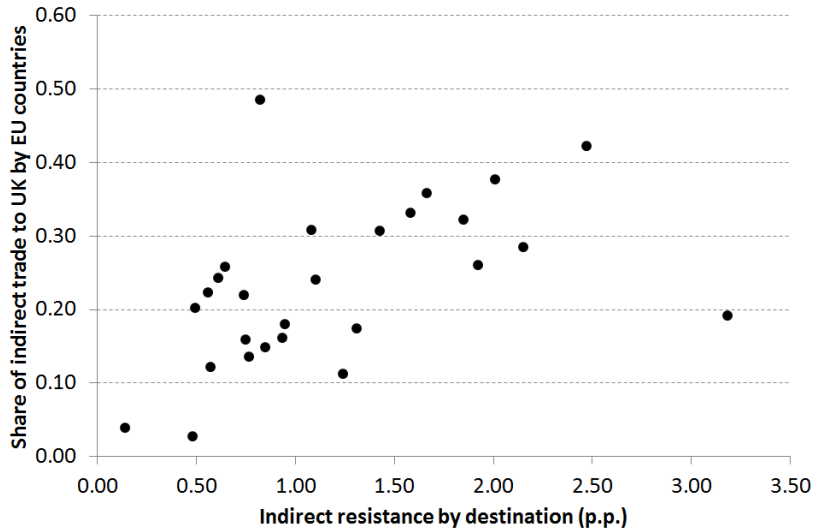

Source: Calculations based on WTO-IDB database and ITC Market Access Map for tariffs, and Comtrade and WIOD for trade.

## 6 Conclusions

On March 29<sup>th</sup> 2019 the United Kingdom (UK) will leave the European Union. Brexit will have significant consequences for the dense network of Global Value Chains (GVCs) that currently spans Europe, across the Channel.

In this paper we present, for the first time, a mapping of such networks, focusing in particular on those GVCs that require back-and-forth trade between the UK and the rest of the Union. Up to two fifths of bilateral export flows are attributable to trade relating to GVCs. We also uncover the indirect Brexit exposure arising from the dense network of intra-EU production and trade linkages.

We construct the whole schedule of tariffs that both the EU and the UK would apply to bilateral trade in the event of a no free-trade agreement between the two economies. We assume that the UK replicates the tariffs currently used by the EU, depending on whether they apply to intermediate or final goods. Tariff on final goods are usually higher than those levied on intermediate goods. Yet the failure to properly account for the back-and-forth-trade in EU-UK GVC may lead to significant underestimation of the actual impact of tariffs.

We compute various indicators of the impact of the indirect tariffs that span from the more traditional cost-push effect to indices of resistance for exporters. Our aim is to provide policymakers with a measure of cost and resistance of trade flows that takes into account the whole EU-UK GVCs structure, in order to clarify the impact of barriers to trade in the negotiations on the future bilateral free trade agreement.

All in all, the total cost-push effect is much higher for the UK, as manufacturing input costs increase by around 0.9 p.p. The corresponding input costs in the EU would be only marginally affected (0.1 p.p.). This result is due to the specific links between the two regions: around one fifth of the total manufacturing inputs, imported and domestic, used by the UK come from the EU, while only 1.5 per cent of the total EU inputs are imported from the UK.

As to the import side, the total tariff would be higher for UK imports from the EU than for EU imports from the UK by around 2 p.p., even taking into account GVCs. However, tariff magnification due to GVCs appears significant just for the European firms. This result is to a large extent due to the fact that the EU exploits the UK to perform some processing stages and imports back these intermediate products with the subsequent amplification of the tariff burden. In the longer run this could induce trade diversion away from the UK (the effect is small for services).

As to the export side, given the density of intra-EU linkages and the sizeable share of indirect trade between the two regions, exporters in both the UK and the EU Member States face higher costs when indirect trade is taken into account. In other words, the export path towards the destination matters, and indirect routes entail tariffs that are not perceived by the exporters (as intra-EU trade is free of tariffs), but account for around 20 per cent of the total costs.

More generally, the methodology used in this paper is not Brexit-specific and it can be applied to any type of tariff; obviously we expect that the magnification effect will be higher, the larger the number of borders on which tariffs will be imposed.

Our analysis has some limitations. Firstly, we adopt a partial equilibrium approach and consequently exclude any trade creation and diversion potentially triggered by EU-UK bilateral tariffs. Secondly, it is an impact assessment exercise:

in the long run we expect that an EU-UK Free Trade Agreement will be signed and tariffs will return substantially to zero. Finally it only concentrates on tariff barriers.

## References

- AMADOR, J., R. CAPPARIELLO, AND R. STEHRER (2015): “Global Value Chains: A View from the Euro Area,” *Asian Economic Journal*, 29, 99–120.
- BALDWIN, R. AND J. LOPEZ-GONZALEZ (2015): “Supply-chain Trade: A Portrait of Global Patterns and Several Testable Hypotheses,” *The World Economy*, 38, 1682–1721.
- BORIN, A. AND M. MANCINI (2016): “Participation in Global Value Chains: Measurement Issues and the Place of Italy,” *Rivista di Politica Economica*, VII-IX.
- (2017): “Follow the Value Added: Tracking Bilateral Relations in Global Value Chains,” MPRA Paper 82692, University Library of Munich, Germany.
- CAPPARIELLO, R. (2017): “Brexit: estimating tariff costs for EU countries in a new trade regime with the UK,” *Questioni di Economia e Finanza (Occasional Papers)* 381, Bank of Italy, Directorate General for Economics, Statistics and Research.
- CARVALHO, V. M. AND N. VOIGTLAENDER (2015): “Input Diffusion and the Evolution of Production Networks,” CEPR Discussion Papers 10498, C.E.P.R. Discussion Papers.
- DHINGRA, S., H. HUANG, G. OTTAVIANO, J. PAULO PESSOA, T. SAMPSON, AND J. VAN REENEN (2017): “The costs and benefits of leaving the EU: trade effects,” *Economic Policy*, 32, 651–705.
- GUERRIERI, P. AND F. VERGARA CAFFARELLI (2012): “Trade Openness and International Fragmentation of Production in the European Union: The New Divide?” *Review of International Economics*, 20, 535–551.
- HUMMELS, D., J. ISHII, AND K.-M. YI (2001): “The nature and growth of vertical specialization in world trade,” *Journal of International Economics*, 54, 75 – 96, trade and Wages.

- JOHNSON, R. C. (2017): “Measuring Global Value Chains,” NBER Working Papers 24027, National Bureau of Economic Research, Inc.
- JOHNSON, R. C. AND G. NOGUERA (2012): “Accounting for intermediates: Production sharing and trade in value added,” *Journal of International Economics*, 86, 224 – 236.
- KEPPEL, C. AND K. PRETTNER (2015): “How interdependent are Eastern European economies and the Euro area?” *The Quarterly Review of Economics and Finance*, 58, 18 – 31.
- KOOPMAN, R., Z. WANG, AND S.-J. WEI (2014): “Tracing Value-Added and Double Counting in Gross Exports,” *American Economic Review*, 104, 459–94.
- LANDESMANN, M., S. LEITNER, AND R. STEHRER (2015): “Competitiveness of the European economy,” EIB Working Papers 2015/01, European Investment Bank (EIB).
- LAWLESS, M. AND E. L. MORGENROTH (2016): “The Product and Sector Level impact of a hard Brexit across the EU,” Tech. rep., ESRI Working paper.
- LEONTIEF, W. W. (1936): “Quantitative Input and Output Relations in the Economic Systems of the United States,” *The Review of Economics and Statistics*, 18, 105–125.
- MIROUDOT, S., D. ROUZET, AND F. SPINELLI (2013): “Trade Policy Implications of Global Value Chains: Case Studies,” OECD Trade Policy Papers 161, OECD Publishing.
- MURADOV, K. (2017): “Trade costs and borders in global value chains,” *Review of World Economics (Weltwirtschaftliches Archiv)*, 153, 487–509.
- OECD (2016): “The Economic Consequences of Brexit: A Taxing Decision,” Economic Policy Papers 16, OECD.
- PISANI, M. AND F. VERGARA CAFFARELLI (2018): “What will Brexit mean for the British and euro-area economies? A model-based assessment of trade

- regimes,” Temi di discussione (Economic working papers) 1163, Bank of Italy, Directorate General for Economics, Statistics and Research.
- ROJAS-ROMAGOSA, H. (2016): “Trade effects of Brexit for the Netherlands,” CPB Background Document June 2016, CPB - Netherlands Bureau for Economic Policy Analysis.
- ROUZET, D. AND S. MIROUDOT (2013): “The Cumulative Impact of Trade Barriers Along The Value Chain: An Empirical Assessment Using the OECD Inter-Country Input-Output Model’,” in *16th Annual Conference on Global Economic Analysis*.
- TIMMER, M. P., E. DIETZENBACHER, B. LOS, R. STEHRER, AND G. J. DE VRIES (2015): “An Illustrated User Guide to the World InputOutput Database: the Case of Global Automotive Production,” *Review of International Economics*, 23, 575–605.
- VANDEBUSSCHE, H., W. CONNELL, AND W. SIMONS (2017): “Global Value Chains, Trade Shocks And Jobs: An Application to Brexit,” Discussion paper DP12303, Centre for Economic Policy Research.

# A Methodology

## A.1 A primer on input-output

The analysis presented in section 3 exploits the basic accounting relationship of the Input-Output framework. In the inter-country Input-Output framework with  $M$  countries and  $N$  sectors, one can assume that a gross output of a country  $s$  is either absorbed in the form of intermediate consumption ( $C$ ) or final-good consumption ( $Y$ ):

$$X_s = C\mu + Y\nu = \sum_r^M c_{sr} + \sum_r^M y_{sr}, \quad (1)$$

where  $X_s$  is an  $N \times 1$  vector of gross output produced by  $N$  sectors in country  $s$ ,  $C$  is a  $N \times NM$  matrix of intermediate consumption according to country and sector of absorption,  $Y$  represents a  $N \times M$  matrix of final consumption by country, and  $\mu$  and  $\nu$  are  $NM \times 1$  and  $M \times 1$  vectors of ones respectively.

By dividing each country's intermediate consumption by its total gross product we can obtain an  $NM \times NM$  matrix of direct input-output (I-O) coefficients  $A$ , where an individual  $N \times N$  block,  $A_{sr}$ , represents country  $r$ 's *production dependency* on inputs provided by sectors in country  $s$ . More specifically, the individual element of each block,  $a(si, rj) = c(si, rj)/X_{rj}$ , expresses the proportion of the total output of a sector  $j$  in country  $r$ , produced with inputs provided by sector  $i$  in country  $s$ . Using a matrix of direct I-O coefficients we can re-express equation 1 as:

$$X = AX + Y \quad (2)$$

Following Leontief's (1936) seminal work, the solution for equation 2 is the Leontief inverse ( $B$ ), which represents both direct and indirect output generated in different stages of production to meet an additional unit of final consumption:

$$X = (I - A)^{-1}Y = BY \quad (3)$$

The starting point of the trade in value-added analysis is the augmentation

of the above identity with direct value-added coefficients corresponding to each particular sector in an individual country. Direct value added coefficients capture the difference between a unit of final product, produced by a particular sector  $j$  in country  $r$ , and the share of intermediate goods used in the process, i.e.  $V_{rj} = 1 - \sum_{i=1}^N \sum_{s \neq r}^M a_{si,rj}$ . Moreover, let  $V_s$  be a  $N \times N$  diagonal matrix with direct sectoral value-added coefficients for particular country on diagonal. The matrix representation of the value-added based input-output identity is then given by the following identity:

$$VX = VBY = \begin{bmatrix} V_1 & 0 & \dots & 0 \\ 0 & V_2 & \dots & 0 \\ \vdots & \vdots & \ddots & \vdots \\ 0 & 0 & \dots & V_M \end{bmatrix} \begin{bmatrix} B_{11} & B_{12} & \dots & B_{1M} \\ B_{21} & B_{22} & \dots & B_{2M} \\ \vdots & \vdots & \ddots & \vdots \\ Y_{M1} & Y_{M2} & \dots & Y_{MM} \end{bmatrix} \begin{bmatrix} Y_{11} & Y_{12} & \dots & Y_{1M} \\ Y_{21} & Y_{22} & \dots & Y_{2M} \\ \vdots & \vdots & \ddots & \vdots \\ Y_{M1} & Y_{M2} & \dots & Y_{MM} \end{bmatrix} \quad (4)$$

Using the inter-country input-output framework derived above, we can define the total gross exports of a country  $s$  as:

$$E_s = \sum_{r \neq s}^G c_{sr} + \sum_{r \neq s}^G y_{sr} \quad (5)$$

Considering instead the country of absorption, where the value added produced in country  $s$  is eventually consumed, we can derive the value-added exports of country  $s$ 's as defined in Johnson and Noguera (2012):

$$VAE_s = \sum_{r \neq s}^G VX_{sr} = V_s \sum_{r \neq s}^G \sum_{g=1}^G B_{sg} Y_{gr} \quad (6)$$

When bilateral balances are of concern, sums are dropped and subindices  $s$  and  $r$  are assigned to specific countries of interest. The same inter-country I-O framework can be used to derive the production dependency of a country  $s$  on products from abroad:

$$A^m(1 - A^d)^{-1}X_s/\tau'X_s, \quad (7)$$

with  $A^m = \sum_{s \neq r}^M A_{sr}$  being a  $N \times N$  matrix of direct input coefficients corresponding to non-domestic sectors,  $A^d = A_{ss}$  is a  $N \times N$  matrix of direct input



coefficients corresponding to domestic sectors, and  $\tau$  is a  $N \times 1$  vector of ones. By replacing the vector of gross output  $X$ , corresponding to the sectoral production of country  $s$ , with the vector of sectoral gross exports  $E$ , we obtain the import content of export as proposed by Hummels et al. (2001):

$$A^m(1 - A^d)^{-1}E_s/\tau' E_s \quad (8)$$

## A.2 Calculation of post-Brexit tariffs

Building on Cappariello (2017), in this study we use data on the EU’s applied MFN tariffs at the product level from the IDB-WTO database. This data source provides the *ad-valorem* tariffs (i.e. charged as a percentage of the value of the imported good) for over 5,000 product lines (defined according to the Harmonised System Nomenclature at 6-digit level, HS6).

However, a number of products, mostly produced in the food and live animals industry and accounting for about 6 per cent of the overall value of UK imports from the EU27, are subject to trade barriers different from tariffs expressed in terms of prices, such as quantity or weight-based tariffs or tariff rate quotas.<sup>29</sup> We have consequently integrated IDB- WTO data with information drawn from the International Trade Centre Market Access Map (ITC MAP), where the burden of these trade barriers has been converted into a common metric. More precisely this latter data set provides the *ad-valorem*-equivalent tariffs imposed on products charged with weight-based tariffs and, in the case of products with tariff rate quotas levied on them, information on tariffs applied to quantities both below and above the quota.<sup>30</sup>

After having constructed the (very long) vector of tariffs, two more steps have been implemented.

First, the tariff rate for each product at the HS6 level has been classified according to the end-use of that product, final or intermediate, by using the Broad

---

<sup>29</sup>In this case, imports below a specified quantity are charged at a lower tariff (the Inside Quota Tariff Rate, IQTR) and imports above that quantity at a higher one (the Outside Quota Tariff Rate, OQTR).

<sup>30</sup>In the case of quotas, we utilise the IQTR under the assumption that the fill rate is lower than the quota, and the quota is not binding.

Economic Category Classification. Second, by combining these tariff data with UN Comtrade data on trade flows in 2014, the average MFN tariffs for the 22 manufacturing sectors in WIOD – for both intermediate and final use – have been calculated by utilising product-level import values as weights.

In general this method suffers from an endogeneity bias, as the import values serving as weights depend on the tariffs themselves. That is, a high tariff rate for a given product may reduce the import value for that product, lowering the tariff rates contribution to the average tariff that is supposed to reflect the overall protection level of the product group. A low tariff produces the opposite effect. Yet, this critique does not apply to our case, because the import flows are pre-tariff (in 2014 the UK was still a member of the EU and hence no tariffs were levied on EU-UK trade).

### A.3 Cumulative tariffs

Consider an import flow in sector  $i$  from country  $e$  to country  $m$  and assume that a direct tariff  $t_{(e,i),m}$  is paid by country  $m$  at the last border. All the backward production linkages must then be taken into account to compute the cumulative tariff. Producers in the exporting country  $e$  paid tariffs on the imported intermediate goods used to produce exports. The amount of foreign intermediate goods embedded in exports is retrieved by the matrix of technical coefficients  $A$ . Each element measures the share of input from a country-sector pair needed to produce one unit of output in another country-sector pair. In other words, each supplier  $g$  in sector  $s$  provides  $a_{(g,s),(e,i)}$  unit of intermediate goods to country  $e$  to produce one unit of sector  $i$  goods. Thus, the exporter in country-sector  $(e, i)$  has paid a tariff on the imported intermediate goods:

$$\sum_{g,s} a_{(g,s),(e,i)} t_{(g,s),e} \quad (9)$$

We can go further upstream and compute the tariffs paid by the  $g$  countries for the imports used to produce the exports destined for country  $e$ , that is:

$$\sum_{g,s,j,u} a_{(g,s),(e,i)} a_{(j,u),(g,s)} t_{(j,u),g} \quad (10)$$

At this stage, the cumulative tariff on country  $m$  is:

$$t_{(e,i),m} + \sum_{g,s} a_{(g,s),(e,i)} t_{(g,s),e} + \sum_{g,s,j,u} a_{(g,s),(e,i)} a_{(j,u),(g,s)} t_{(j,u),g} \quad (11)$$

The total cumulative tariff paid on an import flow along the entire backward production chain is obtained by iterating this process to infinity. In practice, all the direct and indirect uses of foreign intermediate goods in the production of one unit of imports are taken into account by the global Leontief inverse,  $B$ , that is

$$\lim_{n \rightarrow \infty} A^n = (I - A)^{-1} = B. \quad (12)$$

Thus, the *cumulative cost of trade barriers on intermediate goods* is hence defined as the sum of direct tariffs at the last border and direct and of the indirect tariffs on intermediate goods needed to produce this import flow, as follows:<sup>31</sup>

$$CT_{interm} = T_{interm} + (e(A \circ T_{interm})B)' e \quad (13)$$

where  $T_{interm}$  is the tariff matrix for intermediate goods,  $A$  is the matrix of technical coefficients,  $e$  a conformable row vector of ones;  $B$  the global Leontief inverse matrix, and  $\circ$  indicates the Hadamard (or element-by-element) product between matrices.

Furthermore, the *total cumulative cost* might be computed considering both intermediate and final tariffs. Thus,

$$CT_{total} = T_{interm} w_{interm} + T_{final} (1 - w_{interm}) + (e(A \circ T_{interm})B)' e, \quad (14)$$

where  $w_{interm}$  is the share of intermediate goods.

Note that  $CT_{total}$  is a matrix, whose  $e, m$ -th element indicates the cumulative tariff that country  $m$  faces in importing directly and indirectly from country  $e$ . In other terms,  $e, m$ -th element is the total cost-push effect on imported goods from country  $e$  to country  $m$ . Finally, we can compute the indirect tariff share of total tariffs as:  $IT_{S_{total}} = 1 - T_{total}/CT_{total}$ .

---

<sup>31</sup>See Rouzet and Miroudot (2013) for a formal proof.

## B Tables

Table B.1: Gross and value-added exports by country

	Export to UK		UK Export	
	gross	value-added	gross	value-added
Austria	2.6	3.7	0.5	0.6
Belgium	7.3	7.5	2.8	2.0
Bulgaria	2.4	3.5	0.1	0.1
Croatia	2.4	3.3	0.1	0.1
Cyprus	3.8	7.1	0.1	0.1
Czech Rep.	4.2	5.2	0.4	0.4
Denmark	6.3	6.8	1.1	0.9
Estonia	2.5	3.6	0.1	0.1
Finland	4.3	4.6	0.5	0.5
France	7.9	8.1	6.2	6.0
Germany	6.1	6.6	7.2	6.4
Greece	3.2	3.7	0.3	0.5
Hungary	3.9	4.9	0.3	0.2
Ireland	14.2	13.4	4.6	2.6
Italy	5.7	6.4	2.9	3.1
Latvia	4.5	5.1	0.1	0.1
Lithuania	3.9	3.5	0.1	0.1
Luxembourg	2.7	4.1	3.2	0.4
Malta	29.2	26.3	0.3	0.1
Netherlands	7.6	7.8	3.1	2.3
Poland	5.6	6.4	1.0	1.0
Portugal	5.0	5.4	0.4	0.5
Romania	2.8	3.9	0.2	0.3
Slovakia	5.6	7.6	0.1	0.1
Slovenia	1.9	3.0	0.1	0.1
Spain	5.5	5.8	1.7	1.8
Sweden	5.1	5.2	1.6	1.4
EU	6.3	6.7	38.9	31.6

Note: Percentage of total gross and value-added exports. Source: Calculations based on WIOD data.

Table B.2: Production dependency by country

	EU on UK		UK on EU	
	Total	Export	Total	Export
Austria	0.4	0.6	0.1	0.2
Belgium	1.9	2.5	0.5	0.7
Bulgaria	0.5	0.6	0.0	0.0
Croatia	0.5	0.5	0.0	0.0
Cyprus	1.5	2.0	0.0	0.0
Czech Rep.	0.6	0.9	0.1	0.2
Denmark	1.5	1.9	0.2	0.3
Estonia	0.6	0.7	0.0	0.0
Finland	0.8	1.2	0.1	0.1
France	1.1	1.6	1.2	1.6
Germany	0.8	1.2	1.7	2.5
Greece	0.5	0.7	0.0	0.1
Hungary	0.7	0.9	0.1	0.1
Ireland	6.0	6.4	0.5	0.6
Italy	0.6	0.9	0.5	0.8
Latvia	0.6	0.7	0.0	0.0
Lithuania	0.3	0.4	0.0	0.0
Luxembourg	16.5	18.0	0.1	0.1
Malta	8.0	10.0	0.0	0.0
Netherlands	1.3	1.8	1.0	1.3
Poland	0.6	0.7	0.2	0.3
Portugal	0.7	0.9	0.1	0.1
Romania	0.4	0.5	0.0	0.0
Slovakia	0.3	0.4	0.1	0.1
Slovenia	0.4	0.6	0.0	0.0
Spain	0.5	0.9	0.3	0.5
Sweden	1.1	1.8	0.3	0.4
EU	1.1	1.8	7.4	10.0

Source: Calculations based on WIOD data.

Table B.3: Decomposition of GVC-related UK exports to EU by sector

	Total	<i>of which:</i>		<i>of which:</i>	
		Foreign Content		Domestic Content	
			<i>of which:</i> Foreign Content from EU		<i>of which:</i> Reflection to UK
Crop and animal productions	44.0	19.1	8.9	24.8	6.9
Forestry and logging	60.8	30.2	14.6	30.6	8.8
Fishing and aquaculture	36.6	23.4	8.0	13.2	3.2
Mining and quarrying	44.9	14.7	5.1	30.2	4.4
Food products and beverages	35.4	20.1	10.0	15.3	4.9
Textiles and wearing apparel	30.2	18.0	8.4	12.2	1.6
Wood and products of wood	45.4	27.0	14.6	18.4	4.4
Paper products	47.8	24.6	13.4	23.1	4.9
Printing and recorded media	37.5	18.9	10.2	18.7	3.2
Coke and petroleum	67.7	47.7	12.6	20.0	2.0
Chemical products	56.9	34.7	17.8	22.2	2.6
Pharmaceutical products	23.7	16.4	9.3	7.3	1.1
Rubber and plastics	46.7	25.8	13.7	20.9	3.1
Mineral products	39.2	25.8	11.4	13.3	1.9
Basic metals	67.0	41.0	14.9	26.0	2.8
Fabricated metal products	41.6	21.7	8.9	19.9	2.7
Computer and optical products	43.0	28.6	11.0	14.4	1.7
Electrical equipment	46.1	30.6	14.0	15.6	1.9
Machinery and equipment	42.0	27.3	13.1	14.8	1.7
Motor vehicles	46.4	37.4	20.4	9.0	1.2
Other transport equipment	61.4	33.4	10.7	28.0	2.8
Furniture; other manufacturing	29.8	19.8	9.0	10.0	2.0

Note: Percentage of total exports (both GVC-related and not). Source: Calculations based on WIOD data.

Table B.4: Decomposition of GVC-related EU exports to UK by sector

	Total	<i>of which:</i>		<i>of which:</i>	
		Foreign Content	<i>of which:</i> Foreign Content from UK	Domestic Content	<i>of which:</i> Reflection to EU
Crop and animal production	36.4	29.6	5.7	6.8	2.2
Forestry and logging	29.9	15.5	3.2	14.4	4.7
Fishing and aquaculture	35.0	20.9	3.3	14.1	5.0
Mining and quarrying	35.4	7.9	0.8	27.5	8.5
Food products and beverages	28.1	24.7	4.3	3.4	0.8
Textiles and wearing apparel	24.3	18.1	1.7	6.2	1.9
Wood and products of wood	32.9	16.1	2.1	16.8	5.2
Paper products	38.0	15.4	1.7	22.6	7.6
Printing and recorded media	40.6	23.2	2.4	17.4	5.6
Coke and petroleum	63.2	49.1	3.8	14.1	3.9
Chemical products	53.5	25.1	2.5	28.4	9.6
Pharmaceutical products	26.1	18.1	1.7	8.0	2.8
Rubber and plastics	40.9	18.2	2.2	22.7	7.4
Mineral products	32.7	17.5	1.9	15.2	4.7
Basic metals	68.4	24.7	2.4	43.8	11.0
Fabricated metal products	40.2	14.7	1.7	25.4	7.0
Computer and optical products	43.1	29.4	1.9	13.7	4.1
Electrical equipment	36.4	17.3	1.6	19.1	5.8
Machinery and equipment	34.7	15.8	1.5	18.8	5.3
Motor vehicles	29.7	16.7	1.7	13.0	3.9
Other transport equipment	31.1	21.2	2.4	9.9	1.3
Furniture; other manufacturing	20.4	13.5	1.5	6.9	1.9

Note: Percentage of total exports (both GVC-related and not). Source: Calculations based on WIOD data.

Table B.5: Trade linkages between the UK and the EU Member States

	UK EXPORTS			EU EXPORTS		
	direct	through Factory Europe	trough other countries	direct	through Factory Europe	trough other countries
Austria	52.2	38.2	9.5	55.1	37.7	7.2
Belgium	76.6	17.9	5.5	78.6	18.0	3.4
Bulgaria	64.2	25.7	10.1	59.5	28.4	12.0
Croatia	64.2	26.3	9.5	63.9	26.0	10.1
Cyprus	83.2	13.1	3.8	46.7	48.5	4.8
Czech Rep.	62.2	29.9	7.9	64.1	33.1	2.8
Denmark	78.5	15.7	5.8	82.6	12.2	5.2
Estonia	68.1	25.3	6.5	59.7	30.8	9.5
Finland	72.5	21.3	6.1	66.6	25.8	7.6
France	80.0	14.6	5.5	82.7	13.6	3.7
Germany	71.9	20.9	7.2	79.7	15.9	4.5
Greece	68.3	21.4	10.3	72.8	11.3	15.9
Hungary	63.4	28.2	8.4	66.0	30.7	3.3
Ireland	92.9	3.9	3.2	92.7	3.9	3.4
Italy	72.3	20.5	7.2	79.3	16.2	4.5
Latvia	67.4	25.4	7.2	72.5	20.2	7.3
Lithuania	61.8	26.1	12.2	65.1	24.3	10.6
Luxembourg	85.7	10.5	3.8	55.5	35.8	8.8
Malta	81.7	15.7	2.6	96.4	2.8	0.8
Netherlands	78.7	15.1	6.2	75.1	21.9	3.0
Poland	69.8	23.5	6.7	72.9	24.1	3.1
Portugal	71.4	22.4	6.2	76.0	17.4	6.6
Romania	58.0	31.7	10.3	59.7	32.2	8.1
Slovakia	48.0	38.0	14.0	78.8	19.2	2.0
Slovenia	50.7	35.0	14.3	50.6	42.2	7.2
Spain	70.5	20.9	8.6	80.2	14.8	5.1
Sweden	76.0	18.9	5.1	69.1	22.3	8.5
EU	75.5	18.1	6.4	78.4	17.2	4.4

Note: Percentage of value-added exports (both GVC-related and not). Source: Calculations based on WIOD data.



Table B.6: Trade exposure between the UK and the EU Member States

	UK EXPORTS				EU EXPORTS			
	direct	through Factory Europe	through other countries	total	direct	through Factory Europe	through other countries	total
Austria	0.1	0.0	0.0	0.1	0.7	0.5	0.1	1.2
Belgium	0.3	0.1	0.0	0.4	2.4	0.5	0.1	3.1
Bulgaria	0.0	0.0	0.0	0.0	0.8	0.4	0.2	1.3
Cyprus	0.0	0.0	0.0	0.0	1.0	1.1	0.1	2.2
Czech Rep.	0.0	0.0	0.0	0.1	1.5	0.8	0.1	2.3
Germany	1.0	0.3	0.1	1.4	1.7	0.3	0.1	2.1
Denmark	0.1	0.0	0.0	0.2	1.9	0.3	0.1	2.3
Spain	0.3	0.1	0.0	0.4	0.9	0.2	0.1	1.2
Estonia	0.0	0.0	0.0	0.0	0.9	0.5	0.1	1.5
Finland	0.1	0.0	0.0	0.1	0.8	0.3	0.1	1.2
France	1.0	0.2	0.1	1.3	1.4	0.2	0.1	1.7
Greece	0.1	0.0	0.0	0.1	0.5	0.1	0.1	0.7
Croatia	0.0	0.0	0.0	0.0	0.7	0.3	0.1	1.1
Hungary	0.0	0.0	0.0	0.0	1.4	0.7	0.1	2.2
Ireland	0.5	0.0	0.0	0.6	7.0	0.3	0.3	7.5
Italy	0.5	0.1	0.0	0.7	1.1	0.2	0.1	1.4
Lithuania	0.0	0.0	0.0	0.0	1.0	0.4	0.2	1.6
Luxembourg	0.1	0.0	0.0	0.1	1.5	1.0	0.2	2.7
Latvia	0.0	0.0	0.0	0.0	1.3	0.4	0.1	1.8
Malta	0.0	0.0	0.0	0.0	12.0	0.3	0.1	12.4
Netherlands	0.4	0.1	0.0	0.5	2.6	0.7	0.1	3.4
Poland	0.2	0.1	0.0	0.2	1.6	0.5	0.1	2.2
Portugal	0.1	0.0	0.0	0.1	1.0	0.2	0.1	1.3
Romania	0.0	0.0	0.0	0.1	0.7	0.4	0.1	1.2
Slovakia	0.0	0.0	0.0	0.0	2.6	0.6	0.1	3.3
Slovenia	0.0	0.0	0.0	0.0	0.6	0.5	0.1	1.3
Sweden	0.2	0.1	0.0	0.3	1.1	0.4	0.1	1.6
EU	5.1	1.2	0.4	6.7	1.5	0.3	0.1	2.0

Note: value-added exports (both GVC-related and not) as a percentage of GDP. Source: Calculations based on WIOD data.

Table B.7: EU imports from the UK by sector

	tariff			share	
	final	inter-med.	total	final	inter-med.
Crop and animal production	9.8	1.7	3.7	0.39	1.14
Forestry and logging	4.0	0.1	0.6	0.01	0.05
Fishing and aquaculture	9.5	2.8	4.9	0.17	0.37
Mining and quarrying	0.0	0.0	0.0	0.32	7.36
Food products and beverages	13.5	7.4	11.1	6.04	3.78
Textiles and wearing apparel	10.5	6.4	8.8	1.56	1.18
Wood and products of wood	1.3	4.1	3.7	0.03	0.23
Paper products	0.6	0.1	0.2	0.24	0.91
Printing and recorded media	0.0	0.6	0.4	0.15	0.30
Coke and petroleum	0.0	2.4	2.0	0.90	4.11
Chemical products	2.5	4.4	4.0	2.08	8.90
Pharmaceutical products	0.0	0.4	0.1	4.45	2.77
Rubber and plastics	6.0	5.2	5.3	0.55	3.37
Mineral products	9.4	3.0	4.0	0.17	1.01
Basic metals	0.0	1.7	1.6	0.09	6.09
Fabricated metal products	3.4	2.8	2.9	0.45	1.37
Computer and optical products	1.4	0.9	1.2	3.33	3.63
Electrical equipment	2.7	2.3	2.5	1.20	2.65
Machinery and equipment	1.6	2.1	1.9	4.23	4.32
Motor vehicles	10.0	4.5	8.2	7.90	3.66
Other transport equipment	3.7	2.8	3.0	0.87	4.22
Furniture; other manufacturing	1.3	1.0	1.2	2.08	1.36
TOTAL MANUFACTURING	5.8	2.8	3.9	37.21	62.79

Source: Calculations based on WTO-IDB database and ITC Market Access Map for tariffs, and Comtrade and WIOD for trade.

Table B.8: UK imports from the EU by sector

	tariff			share	
	final	inter-med.	total	final	inter-med.
Crop and animal production	7.8	1.0	5.5	2.24	1.14
Forestry and logging	10.4	0.2	1.5	0.01	0.05
Fishing and aquaculture	10.0	4.2	6.3	0.01	0.02
Mining and quarrying	0.0	0.0	0.0	0.02	1.20
Food products and beverages	18.7	11.2	17.6	11.74	1.86
Textiles and wearing apparel	9.9	6.2	9.2	2.79	0.70
Wood and products of wood	1.6	2.2	2.2	0.06	1.08
Paper products	1.6	0.0	0.2	0.31	2.00
Printing and recorded media	0.0	0.3	0.2	0.03	0.08
Coke and petroleum	0.0	2.4	1.8	1.08	3.52
Chemical products	2.3	4.8	4.4	1.48	6.75
Pharmaceutical products	0.0	0.7	0.4	2.38	4.99
Rubber and plastics	5.8	5.3	5.4	0.56	2.76
Mineral products	10.1	3.1	3.7	0.12	1.19
Basic metals	0.0	2.2	2.0	0.25	2.56
Fabricated metal products	3.1	2.8	2.9	0.94	2.02
Computer and optical products	2.5	1.4	1.8	2.50	4.23
Electrical equipment	2.7	2.5	2.6	1.31	2.59
Machinery and equipment	1.7	1.9	1.8	4.36	3.73
Motor vehicles	10.0	5.9	8.6	11.56	5.83
Other transport equipment	5.2	3.0	4.8	3.85	0.90
Furniture; other manufacturing	1.5	1.3	1.5	2.51	0.69
TOTAL MANUFACTURING	8.6	3.2	5.9	50.10	49.90

Source: Calculations based on WTO-IDB database and ITC Market Access Map for tariffs, and Comtrade and WIOD for trade.

Table B.9: UK imports from the EU by country

	tariff			share	
	final	inter-med.	total	final	inter-med.
Austria	5.9	3.1	4.3	0.62	0.82
Belgium	8.9	3.8	6.2	3.12	3.51
Bulgaria	6.4	3.6	4.8	0.06	0.07
Croatia	16.9	2.8	7.8	0.02	0.05
Cyprus	12.3	1.5	9.9	0.02	0.01
Czech Rep.	7.7	2.5	5.2	1.03	1.01
Denmark	9.6	1.5	5.8	1.13	1.02
Estonia	2.3	1.7	1.8	0.02	0.07
Finland	1.5	1.9	1.8	0.32	0.98
France	6.7	3.8	5.3	6.11	5.81
Germany	7.5	3.0	5.2	14.97	14.99
Greece	6.5	3.5	5.0	0.09	0.10
Hungary	6.3	3.3	4.6	0.51	0.66
Ireland	17.4	4.4	12.8	6.04	3.36
Italy	6.9	3.4	5.4	4.94	3.89
Latvia	4.5	1.4	1.8	0.02	0.11
Lithuania	6.0	3.2	4.2	0.15	0.27
Luxembourg	4.8	2.2	2.7	0.02	0.07
Malta	3.9	2.2	3.0	0.01	0.01
Netherlands	7.5	2.8	4.5	3.15	5.62
Poland	7.8	3.1	5.5	1.71	1.66
Portugal	9.3	3.7	6.8	0.51	0.41
Romania	8.9	3.0	6.3	0.27	0.21
Slovakia	10.1	3.4	8.4	0.64	0.21
Slovenia	3.8	2.8	3.2	0.06	0.09
Spain	8.6	4.0	6.6	3.49	2.62
Sweden	3.2	2.2	2.5	1.08	2.27
EU	8.6	3.2	5.9	50.10	49.90

Source: Calculations based on WTO-IDB database and ITC Market Access Map for tariffs, and Comtrade and WIOD for trade.

Table B.10: EU imports from the UK by country

	tariff			share	
	final	inter-med.	total	final	inter-med.
Austria	5.1	3.8	4.3	0.52	0.77
Belgium	6.3	3.0	4.1	2.29	4.32
Bulgaria	4.1	3.5	3.8	0.16	0.13
Croatia	4.0	3.5	3.8	0.07	0.04
Cyprus	9.2	2.5	8.0	0.26	0.06
Czech Rep.	4.3	2.9	3.4	0.43	0.93
Denmark	4.2	2.8	3.2	0.77	1.65
Estonia	2.8	3.1	2.9	0.13	0.07
Finland	5.8	2.2	3.6	0.53	0.87
France	5.8	2.4	3.6	5.04	8.97
Germany	5.0	2.6	3.4	7.93	15.72
Greece	5.8	1.8	4.7	0.59	0.25
Hungary	7.0	2.5	3.9	0.25	0.53
Ireland	6.7	4.0	5.0	4.67	7.82
Italy	6.1	2.3	3.7	2.50	4.36
Latvia	4.3	3.0	3.8	0.11	0.07
Lithuania	4.9	3.3	4.2	0.15	0.12
Luxembourg	5.7	3.7	4.0	0.05	0.31
Malta	8.1	2.2	5.3	0.11	0.10
Netherlands	7.3	3.1	4.6	3.25	5.99
Poland	4.1	3.1	3.6	1.52	1.63
Portugal	5.9	2.3	4.1	0.53	0.52
Romania	3.1	3.7	3.5	0.25	0.37
Slovakia	3.8	3.1	3.3	0.13	0.24
Slovenia	4.8	3.6	4.1	0.07	0.10
Spain	5.9	1.8	3.7	3.22	3.90
Sweden	5.5	2.0	3.3	1.69	2.96
EU	5.8	2.8	3.9	37.21	62.79

Source: Calculations based on WTO-IDB database and ITC Market Access Map for tariffs, and Comtrade and WIOD for trade.

Table B.11: Tariff magnification effect - cumulated tariffs on goods.

EU imports from the UK

	simple tariff	cumulated tariff	difference in p.p.
Crop and animal production	3.73	4.05	0.31
Forestry and logging	0.58	0.96	0.37
Fishing and aquaculture	4.93	5.18	0.25
Mining and quarrying	0.00	0.09	0.09
Food products and beverages	11.14	11.50	0.35
Textiles and wearing apparel	8.76	9.12	0.36
Wood and products of wood	3.73	4.12	0.39
Paper products	0.18	0.44	0.26
Printing and recorded media	0.40	0.62	0.22
Coke and petroleum	2.00	2.19	0.19
Chemical products	4.05	4.86	0.82
Pharmaceutical products	0.15	0.26	0.11
Rubber and plastics	5.30	5.91	0.61
Mineral products	3.95	4.29	0.33
Basic metals	1.64	2.00	0.36
Fabricated metal products	2.91	3.16	0.25
Computer and optical products	1.16	1.39	0.23
Electrical equipment	2.45	2.86	0.41
Machinery and equipment	1.87	2.22	0.36
Motor vehicles	8.24	9.18	0.94
Other transport equipment	2.99	3.26	0.27
Furniture; other manufacturing	1.18	1.44	0.26
TOTAL MANUFACTURING	3.88	4.30	0.42

Source: Calculations based on WTO-IDB database and ITC Market Access Map for tariffs, and Comtrade and WIOD for trade.

Table B.12: Tariff magnification effect - cumulated tariffs on goods.

UK imports from the EU

	simple tariff	cumulated tariff	difference in p.p.
Crop and animal production	5.51	5.64	0.13
Forestry and logging	1.48	1.56	0.07
Fishing and aquaculture	6.34	6.42	0.07
Mining and quarrying	0.00	0.01	0.01
Food products and beverages	17.65	17.83	0.18
Textiles and wearing apparel	9.19	9.23	0.04
Wood and products of wood	2.19	2.24	0.05
Paper products	0.23	0.26	0.03
Printing and recorded media	0.25	0.28	0.03
Coke and petroleum	1.84	1.89	0.05
Chemical products	4.38	4.46	0.08
Pharmaceutical products	0.44	0.47	0.03
Rubber and plastics	5.40	5.48	0.08
Mineral products	3.73	3.77	0.03
Basic metals	1.96	2.00	0.04
Fabricated metal products	2.86	2.89	0.03
Computer and optical products	1.83	1.86	0.03
Electrical equipment	2.58	2.62	0.04
Machinery and equipment	1.80	1.84	0.03
Motor vehicles	8.62	8.67	0.06
Other transport equipment	4.78	4.84	0.07
Furniture; other manufacturing	1.46	1.49	0.03
TOTAL MANUFACTURING	5.93	6.00	0.07

Source: Calculations based on WTO-IDB database and ITC Market Access Map for tariffs, and Comtrade and WIOD for trade.

Table B.13: Tariff magnification effect - cumulated tariffs on services

	UK imports from the EU	EU imports from the UK
Repair and installation	0.03	0.23
Electricity, gas and steam	0.01	0.13
Water collection	0.01	0.08
Sewerage; waste collection	0.01	0.08
Construction	0.03	0.18
Motor vehicle trade	0.02	0.26
Wholesale trade	0.01	0.11
Retail trade	0.01	0.09
Land transport and pipelines	0.02	0.15
Water transport	0.02	0.07
Air transport	0.05	0.12
Warehousing	0.01	0.08
Postal and courier	0.01	0.11
Accommod. and food service	0.02	0.22
Publishing activities	0.07	0.09
Picture, video and TV	0.01	0.08
Telecommunications	0.01	0.13
Computer programming	0.01	0.05
Financial service activities	0.01	0.04
Insurance and pension fund	0.01	0.05
Auxiliary services	0.02	0.05
Real estate activities	0.00	0.03
Legal and accounting	0.01	0.04
Architectural and engineering	0.01	0.05
Scientific research	0.01	0.08
Advertising	0.01	0.06
Other professional activities	0.01	0.06
Administrative activities	0.01	0.10
Public administration	0.01	0.08
Education	0.00	0.05
Human health; Social work	0.01	0.11
Other service activities	0.01	0.06
Other activities	0.00	0.00
<b>TOTAL SERVICES</b>	<b>0.01</b>	<b>0.08</b>

Source: Calculations based on WTO-IDB database and ITC Market Access Map for tariffs, and Comtrade and WIOD for trade.



Table B.14: Tariff magnification effect - cumulated tariffs by country

	UK imports of goods			Goods imports from the UK		
	simple tariff	cumul. tariff	differ. in p.p.	simple tariff	cumul. tariff	differ. in p.p.
Austria	4.32	4.35	0.04	4.30	4.83	0.53
Belgium	6.19	6.27	0.08	4.13	4.60	0.47
Bulgaria	4.84	4.87	0.02	3.82	4.22	0.41
Croatia	7.75	7.77	0.01	3.80	4.22	0.42
Cyprus	9.93	9.95	0.02	7.98	8.47	0.49
Czech Rep.	5.17	5.20	0.04	3.36	3.81	0.44
Denmark	5.75	5.79	0.04	3.24	3.59	0.35
Estonia	1.80	1.82	0.02	2.88	3.32	0.44
Finland	1.80	1.82	0.03	3.56	4.01	0.45
France	5.28	5.32	0.04	3.63	4.03	0.40
Germany	5.21	5.25	0.04	3.36	3.80	0.43
Greece	5.01	5.02	0.01	4.66	5.04	0.38
Hungary	4.58	4.61	0.03	3.91	4.32	0.42
Ireland	12.79	13.11	0.33	5.01	5.39	0.38
Italy	5.38	5.40	0.02	3.71	4.13	0.42
Latvia	1.83	1.85	0.02	3.82	4.18	0.36
Lithuania	4.15	4.17	0.02	4.21	4.63	0.42
Luxembourg	2.73	2.77	0.05	4.00	4.43	0.42
Malta	3.01	3.08	0.07	5.29	5.69	0.40
Netherlands	4.45	4.52	0.07	4.55	4.99	0.43
Poland	5.50	5.53	0.03	3.58	4.00	0.43
Portugal	6.81	6.84	0.03	4.11	4.52	0.42
Romania	6.31	6.34	0.03	3.46	3.90	0.44
Slovakia	8.43	8.46	0.03	3.32	3.76	0.44
Slovenia	3.23	3.26	0.03	4.08	4.53	0.45
Spain	6.60	6.64	0.03	3.66	4.07	0.41
Sweden	2.54	2.58	0.03	3.30	3.70	0.39
EU	5.93	6.00	0.07	3.88	4.30	0.42

Source: Calculations based on WTO-IDB database and ITC Market Access Map for tariffs, and Comtrade and WIOD for trade.

Table B.15: Tariff magnification effect - cumulated tariffs to third countries

	UK exports	UK imports	EU exports	EU imports
Australia	0.45	0.00	0.04	0.00
Brazil	0.44	0.00	0.04	0.00
Canada	0.32	0.00	0.04	0.00
Chile	0.46	0.01	0.04	0.02
China	0.37	0.00	0.04	0.00
India	0.36	0.01	0.04	0.00
Indonesia	0.43	0.00	0.04	0.00
Japan	0.36	0.00	0.04	0.00
Mexico	0.48	0.00	0.05	0.00
Norway	0.33	0.00	0.04	0.01
Russia	0.54	0.00	0.04	0.00
South Korea	0.26	0.00	0.04	0.00
Taiwan	0.39	0.00	0.04	0.00
Turkey	0.53	0.01	0.04	0.01
USA	0.39	0.00	0.05	0.00
Rest of the world	0.29	0.00	0.04	0.00

Source: Calculations based on WTO-IDB database and ITC Market Access Map for tariffs, and Comtrade and WIOD for trade.

Table B.16: Cost increase due to manufacturing inputs: by country

	without GVC	with GVC	share of indirect costs
United Kingdom	0.64	0.86	25.72
Austria	0.02	0.06	55.35
Belgium	0.09	0.14	36.62
Bulgaria	0.02	0.04	50.60
Cyprus	0.04	0.06	36.18
Czech Rep.	0.03	0.06	55.77
Germany	0.04	0.08	48.59
Denmark	0.07	0.10	37.20
Spain	0.02	0.04	57.44
Estonia	0.02	0.05	52.44
Finland	0.02	0.05	55.04
France	0.04	0.07	47.38
Greece	0.01	0.02	54.01
Croatia	0.01	0.03	60.47
Hungary	0.02	0.05	58.73
Ireland	0.83	0.96	14.07
Italy	0.02	0.04	58.56
Lithuania	0.03	0.05	44.87
Luxembourg	0.14	0.20	28.81
Latvia	0.02	0.04	47.79
Malta	0.08	0.12	34.38
Netherlands	0.08	0.12	35.56
Poland	0.02	0.05	55.73
Portugal	0.02	0.04	55.70
Romania	0.02	0.04	50.64
Slovakia	0.01	0.04	65.93
Slovenia	0.02	0.05	52.16
Sweden	0.05	0.09	43.14
EU	0.04	0.08	44.06
Australia	0.00	0.01	100.00
Brazil	0.00	0.00	100.00
Canada	0.00	0.01	100.00
Chile	0.00	0.03	100.00
China	0.00	0.00	100.00
Indonesia	0.00	0.00	100.00
India	0.00	0.00	100.00
Japan	0.00	0.00	100.00
South Korea	0.00	0.00	100.00
Mexico	0.00	0.00	100.00
Norway	0.00	0.03	100.00
Russia	0.00	0.01	100.00
Turkey	0.00	0.01	100.00
Taiwan	0.00	0.00	100.00
USA	0.00	0.01	100.00
Rest of the world	0.00	0.01	100.00

Source: Calculations based on WTO-IDB database and ITC Market Access Map for tariffs, and Comtrade and WIOD for trade.

Table B.17: Cost increase due to manufacturing inputs: by sector

	United Kingdom			European Union		
	without GVC	with GVC	share of indirect costs	without GVC	with GVC	share of indirect costs
Crop and animal production	0.1	0.4	73.12	0.0	0.0	76.55
Forestry and logging	0.0	0.3	94.37	0.0	0.0	98.83
Fishing and aquaculture	0.2	0.3	50.64	0.1	0.2	20.23
Mining and quarrying	0.0	0.0	99.79	0.0	0.0	99.68
Food products and beverages	0.6	0.9	36.19	0.1	0.1	26.96
Textiles and wearing apparel	0.9	1.2	21.05	0.1	0.1	25.30
Wood and products of wood	0.5	0.8	37.48	0.0	0.0	64.59
Paper products	0.0	0.2	97.42	0.0	0.0	98.50
Printing and recorded media	0.0	0.2	97.45	0.0	0.0	87.60
Coke and petroleum	0.6	0.7	10.47	0.0	0.1	46.65
Chemical products	1.8	2.2	18.74	0.1	0.2	41.52
Pharmaceutical products	0.3	0.3	15.46	0.0	0.0	63.36
Rubber and plastics	1.1	1.5	29.23	0.1	0.1	41.58
Mineral products	0.4	0.6	42.95	0.0	0.0	51.00
Basic metals	0.7	0.7	4.81	0.0	0.1	53.65
Fabricated metal products	0.3	0.5	40.92	0.0	0.0	67.76
Computer and optical products	0.4	0.4	15.08	0.0	0.0	46.32
Electrical equipment	0.9	1.1	13.95	0.0	0.1	43.24
Machinery and equipment	0.6	0.8	22.13	0.0	0.1	43.73
Motor vehicles	2.5	3.0	14.77	0.1	0.1	46.26
Other transport equipment	0.4	0.5	15.27	0.2	0.2	25.56
Furniture; other manufacturing	0.2	0.4	56.79	0.0	0.1	59.27

Source: Calculations based on WTO-IDB database and ITC Market Access Map for tariffs, and Comtrade and WIOD for trade.

Table B.18: Cumulated tariffs at origin by country: UK exports

	value of direct tariff	value of indirect tariff	share of indirect tariff on total
Austria	37.9	24.8	0.40
Belgium	167.4	45.4	0.21
Bulgaria	6.0	2.7	0.31
Croatia	2.0	1.9	0.49
Cyprus	1.8	0.5	0.20
Czech Rep.	35.6	20.0	0.36
Denmark	60.6	14.7	0.20
Estonia	2.8	1.9	0.40
Finland	25.0	10.4	0.29
France	284.4	83.5	0.23
Germany	526.1	167.3	0.24
Greece	5.7	3.2	0.36
Hungary	17.2	14.0	0.45
Ireland	407.4	7.1	0.02
Italy	132.9	57.1	0.30
Latvia	2.5	1.2	0.32
Lithuania	5.2	2.0	0.28
Luxembourg	15.2	5.5	0.27
Malta	2.7	0.9	0.25
Netherlands	242.2	45.0	0.16
Poland	65.5	28.5	0.30
Portugal	15.6	8.0	0.34
Romania	18.1	8.0	0.31
Slovakia	9.7	9.8	0.50
Slovenia	4.6	2.7	0.37
Spain	93.5	36.6	0.28
Sweden	78.7	18.2	0.19
EU total	2266.4	620.8	0.22

Note: EU Total is the sum of the Member States. Tariff values in millions of current US dollars. Source: Calculations based on WTO-IDB database and ITC Market Access Map for tariffs, and Comtrade and WIOD for trade.

Table B.19: Cumulated tariffs at destination by country: EU exports

	value of direct tariff	value of indirect tariff	share of indirect tariff on total
Austria	70.8	56.7	0.44
Belgium	374.5	120.7	0.24
Bulgaria	7.4	6.0	0.45
Croatia	3.5	3.4	0.49
Cyprus	0.2	0.8	0.79
Czech Rep.	70.9	49.8	0.41
Denmark	43.1	24.4	0.36
Estonia	3.2	2.9	0.47
Finland	52.3	20.6	0.28
France	621.9	170.7	0.22
Germany	1248.1	357.3	0.22
Greece	9.7	4.7	0.32
Hungary	60.2	31.0	0.34
Ireland	417.0	21.9	0.05
Italy	371.7	116.2	0.24
Latvia	4.5	2.3	0.34
Lithuania	24.4	5.8	0.19
Luxembourg	4.4	16.1	0.78
Malta	0.9	1.2	0.56
Netherlands	432.3	197.1	0.31
Poland	144.1	69.6	0.33
Portugal	43.1	17.3	0.29
Romania	17.5	16.3	0.48
Slovakia	19.6	21.1	0.52
Slovenia	6.9	7.4	0.52
Spain	293.1	72.4	0.20
Sweden	142.0	46.4	0.25
EU total	4487.4	1459.8	0.25

Note: EU Total is the sum of the Member States. Tariff values in millions of current US dollars. Source: Calculations based on WTO-IDB database and ITC Market Access Map for tariffs, and Comtrade and WIOD for trade.

## C List of countries and sectors

We consider all the countries included in the WIOD database:

- **European Union (EU):** Austria, Belgium, Bulgaria, Croatia, Cyprus, Czech Republic, Denmark, Estonia, Finland, France, Germany, Greece, Hungary, Ireland, Italy, Latvia, Lithuania, Luxembourg, Malta, Netherlands, Poland, Portugal, Romania, Slovakia, Slovenia, Spain, and Sweden.
- **United Kingdom (UK).**
- **Rest of World:** Australia, Brazil, Canada, Chile, China, India, Indonesia, Japan, Mexico, Norway, Poland, Romania, Russia, South Korea, Sweden, Turkey, Taiwan, USA, Rest of the World.

Table C.20: List of WIOD sectors: Manufacturing

Code	Description
A01	Crop and animal production
A02	Forestry and logging
A03	Fishing and aquaculture
B	Mining and quarrying
C10-C12	Food products and beverages
C13-C15	Textiles and wearing apparel
C16	Wood and products of wood
C17	Paper products
C18	Printing and recorded media
C19	Coke and petroleum
C20	Chemical products
C21	Pharmaceutical products
C22	Rubber and plastics
C23	Mineral products
C24	Basic metals
C25	Fabricated metal products
C26	Computer and optical products
C27	Electrical equipment
C28	Machinery and equipment
C29	Motor vehicles
C30	Other transport equipment
C31-C32	Furniture; other manufacturing



Table C.21: List of WIOD sectors: Services

Code	Description
C33	Repair and installation
D35	Electricity, gas and steam
E36	Water collection
E37-E39	Sewerage; waste collection
F	Construction
G45	Motor vehicle trade
G46	Wholesale trade
G47	Retail trade
H49	Land transport and pipelines
H50	Water transport
H51	Air transport
H52	Warehousing
H53	Postal and courier
I	Accommodation and food service
J58	Publishing activities
J59-J60	Picture, video and TV
J61	Telecommunications
J62-J63	Computer programming
K64	Financial service activities
K65	Insurance and pension fund
K66	Auxiliary services
L68	Real estate activities
M69-M70	Legal and accounting
M71	Architectural and engineering
M72	Scientific research
M73	Advertising
M74-M75	Other professional activities
N	Administrative activities
O84	Public administration
P85	Education
Q	Human health and social work
R-S	Other service activities